



A LANDOWNER'S GUIDE FOR
WILD PIG MANAGEMENT
PRACTICAL METHODS FOR WILD PIG CONTROL

Bill Hamrick, Mark Smith, Chris Jaworowski, & Bronson Strickland

Mississippi State University Extension Service &
Alabama Cooperative Extension System

ACKNOWLEDGMENTS

We thank USDA/National Institute of Food and Agriculture, the Renewable Resources Extension Act (RREA), the Alabama Wildlife Federation, Mississippi State University, Auburn University, Alabama Department of Conservation and Natural Resources, and Mississippi Department of Wildlife, Fisheries and Parks for their financial and moral support of this publication. The authors also acknowledge with gratitude the contributions of Scott Alls, Carl Betsill, Jay Cumbee, Kris Godwin, Parker Hall, and Dana Johnson, USDA/APHIS-Wildlife Services; Billy Higginbotham, Texas AgriLife Extension Service; Sherman “Skip” Jack, Mississippi State University—College of Veterinary Medicine; Joe Corn, Southeastern Cooperative Wildlife Disease Study; Ricky Flynt and Brad Young, Mississippi Department of Wildlife, Fisheries, & Parks; Ben West, University of Tennessee Extension Service; Jack Mayer, Savannah River National Laboratory.

The mention of commercial products in this publication is for the reader’s convenience and is not intended as an endorsement of those products nor discrimination against similar products not mentioned.

To obtain additional copies of this publication, please visit <http://www.wildpiginfo.com/resources/> or <http://msucares.com/pubs>, where an electronic copy can be downloaded at no charge.

Printed copies may also be ordered through Mississippi State University Extension Service and Alabama Cooperative Extension System.

- Mississippi State University Extension Service: Contact your County Extension office.
- Alabama Cooperative Extension System: Call (334) 844-1592 or e-mail publications@aces.edu

Published by

Mississippi State University Extension Service and

Alabama Cooperative Extension System, Alabama A&M University and Auburn University

Several cover photos provided by Chris Jaworowski, Dee Mincey, Randy DeYoung, Ronald Britnell, & Bill Hamrick
Editing by Tom Knecht, Words by Tom
Design and Layout by Kathy Jacobs Design & Marketing

CONTENTS

Introduction	1
Range Expansion	2
Damage	6
Agricultural Damage	7
Forest Damage	7
Threats to Native Wildlife	8
Environmental Damage	8
Learn to Recognize the Signs.....	9
Wild Pigs and Disease	12
Disease Prevention	12
Management	14
Trapping Wild Pigs	14
Scouting the Trap Location	15
Prebaiting.....	15
Choosing a Bait	16
Baiting and Setting the Trap	16
Types of Pig Traps	17
Box Traps.....	18
Cage Traps.....	19
Corral Traps	19
Trap Door Designs	21
Single-Catch Trap Doors.....	21
Multicatch Trap Doors.....	23
Trigger Mechanisms	24
Root Sticks	24
Trip Wires	24
Snaring Wild Pigs.....	25
Euthanizing Wild Pigs	25
Shooting and Hunting Wild Pigs	27
Nontarget Species.....	27
Where Do We Go From Here?	30
Appendix I: Zoonotic Diseases	31
Appendix II: Trap Baiting Strategies	32
Appendix III: Trap and Door Designs, Trip Wire Routing, and Baiting	34
Glossary	41
Authors	42

Guest Articles

Disease Impacts of Wild Pigs	13
Using Remote- Sensing Cameras to Enhance Wild Pig Trapping Efficiency	17
Trip Wires Versus Root Sticks	25
Night Time Ops For Wild Pig Control.....	26
Hunting Pigs With Dogs.....	29

INTRODUCTION

Wild pigs are not native to the Americas. They were first introduced to the United States in the 1500s by the Spanish explorer Hernando DeSoto, who traveled extensively throughout the Southeast.

Because pigs are highly adaptable and capable of fending for themselves, they were a popular livestock species for early explorers and settlers. In the centuries following European exploration and colonization of the eastern United States, settlers, farmers, and some Native Americans continued to promote the spread of pigs by using free-range

Wild pigs are not native to the Americas.



livestock management practices. In the early 1900s, Eurasian or Russian wild boar were introduced into portions of the United States for hunting purposes. As a result of cross-breeding with wild domestic stock, many hybrid populations now exist throughout the wild pig's range.



Alabama DCNR, Wildlife and Freshwater Fisheries Division, Chris Jaworowski



“Wild pig” is a collective term used to refer to feral domestic pigs (left), Eurasian wild boar (right), and hybrids resulting from interbreeding of the two. As a result of interbreeding and their diverse background, wild pigs come in a variety of colors and sizes.

RANGE EXPANSION

Today, wild pigs are both numerous and widespread throughout much of the United States, with populations in at least 45 states. Historically, problems with wild pigs were limited mostly to the southeastern states, California, Hawaii, and Texas. However, in the last 20 years wild pig ranges have expanded dramatically to include much of the United States, and populations now exist in such northerly climates as Michigan, North Dakota, and Oregon. This current distribution of wild pigs, almost nationwide in scope, is not a consequence of natural events. Instead, it has resulted largely from translocation of wild pigs by humans and from “the nature of the beast.”

THE HUMAN FACTOR

The popularity of wild pigs as a game species has played a major role in the expansion of their range throughout the United States. In some cases, the sudden presence of wild pigs in an area where they previously did not exist can be attributed to escapes of stocked animals from privately owned, “game-proof” fenced hunting preserves. In other cases, the sudden presence of wild pigs is a result of illegal translocation: the practice of capturing wild pigs, transporting them to new locations, and releasing them into the wild.

One group that continues to fuel this practice consists of irresponsible and uninformed pig-hunting enthusiasts whose goal is to establish local wild pig populations for recreational hunting. A second group comprises those whose goal is to profit from the capture and sale of wild pigs

Wild pigs are both numerous and widespread throughout North America, with populations in at least 45 states.



to hunting enthusiasts. Because wild pigs are such intelligent animals, trapping those that have been previously captured and released is often a daunting challenge, contributing to the spread of this nonnative, highly invasive species.

THE NATURE OF THE BEAST: BIOLOGICAL AND BEHAVIORAL TRAITS

Pigs possess many biological and behavioral traits that enable them to live just about anywhere and quickly populate new areas.

1. Wild pigs are habitat generalists, meaning that they are highly adaptable and can live in many different habitat types throughout a landscape or region. They can tolerate a wide range of different climates, ranging from the hot, dry deserts of Mexico to the subzero temperatures of the extreme northern United States and Canada.
2. Wild pigs are opportunistic omnivores.
 - They eat mostly plant matter and invertebrate animals such as worms, insects, and insect larvae.
 - When the opportunity presents itself, wild pigs will eat small mammals, the young of larger mammals, and the eggs and young of ground-nesting birds and reptiles.



Adapted from Feral/Wild Swine Populations, SCWDS

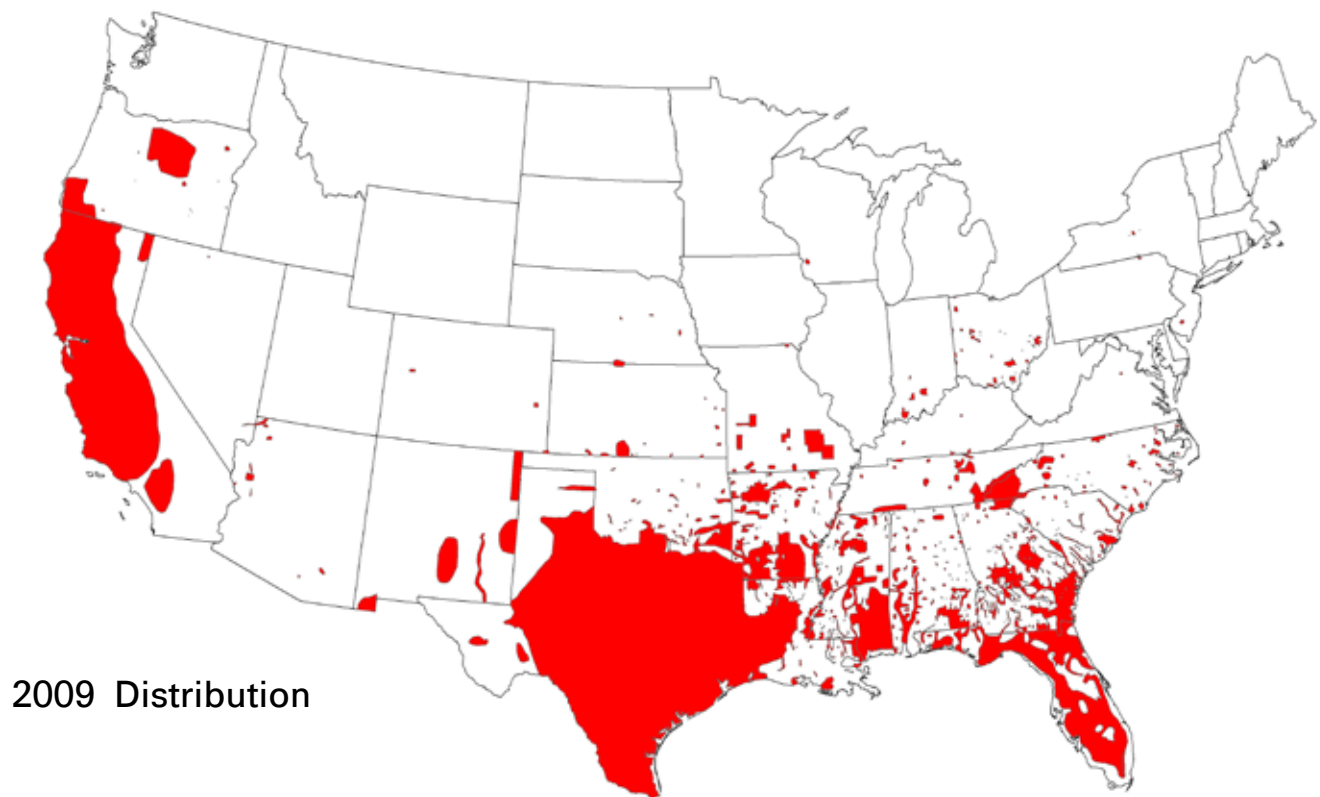

Wild pigs are numerous and widespread across the United States; shaded areas on the map represent established breeding populations. Notice the progression northward and the small isolated populations in the far northern states, many miles from previously established populations.

Wild pigs are habitat generalists, meaning that they are highly adaptable and can live in many different habitat types throughout a landscape or region.



USDA/APHIS/Wildlife Services, Dana Johnson

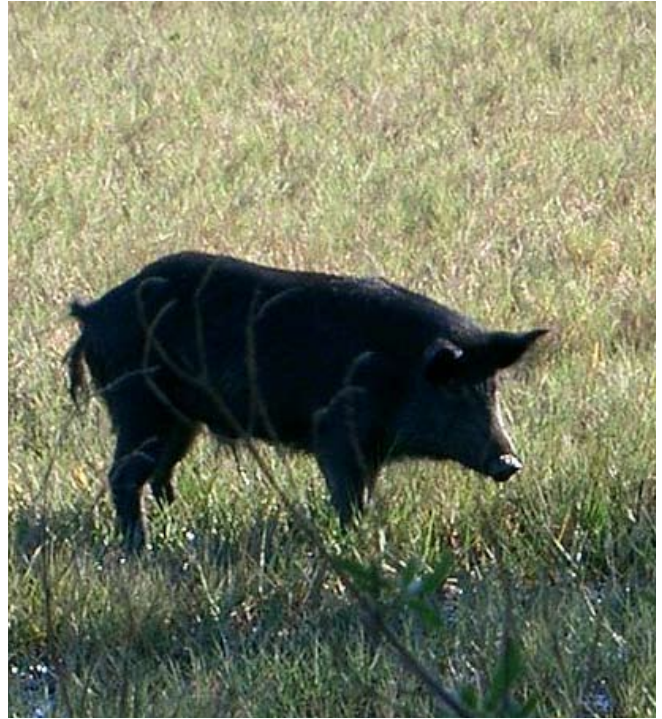

Mississippi State University Extension Service, Bill Hamrick



Texas A & M University-Kingsville, Randy DeYoung



Given food, water, and cover, wild pigs can live almost anywhere. Clockwise from top left; bottomland hardwood swamps, coastal marshes and barrier islands of the southeastern U.S., prairie and mixed forest provinces of the northern U.S. and southern Canada, and desert regions of the southwestern U.S. and Mexico.

3. Wild pigs have a high reproductive potential.
 - They reach sexual maturity as early as 6 months of age.
 - Litter sizes average about six piglets but range from three to eight piglets.
 - Females can farrow twice per year.
4. Wild pigs have low natural mortality.
 - They are most vulnerable to predation when they are young. Once pigs reach about 40 pounds, few predators pose a serious threat.
 - Although diseases and parasites have some affect on wild pig populations, their impacts are not well known and the factors involved are poorly understood.
 - The highest rates of wild pig mortality are a result of human activities: hunting, trapping, and automobile collisions.



Jay Cumbee, SCWDS

The expansion of wild pig ranges across the U.S. during the last 20 years is mostly a result of human activities, such as illegal translocation of wild pigs and escapes from fenced hunting preserves that offer wild boar hunts.

What Do Wild Pigs Eat?

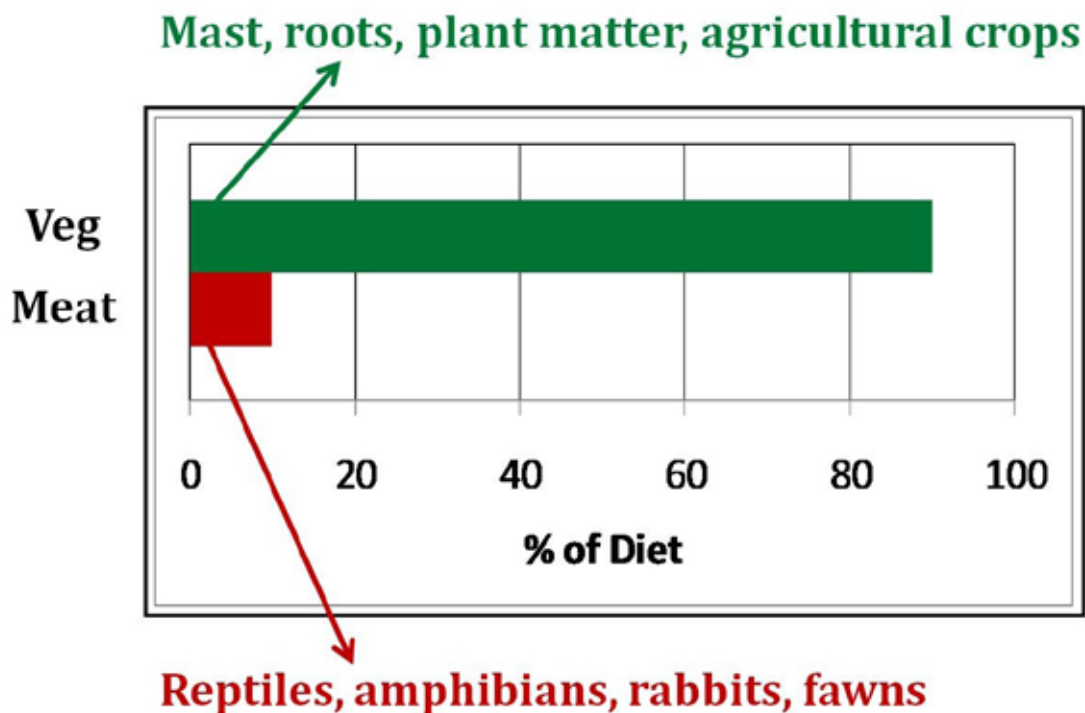

Adapted from: Schley, L. and T. J. Roper (2003). Diet of Wild Boar *Sus scrofa* in Western Europe, with particular reference to consumption of agricultural crops. *Mammal Review* 33: 43-56.

Wild pigs are opportunistic omnivores. This graph shows what wild pigs can do to vegetation and local fauna.

DAMAGE

Damage from pigs is nothing new, and wherever wild pigs are present, they inevitably become a problem. Although pigs were an important food source for early Americans, they also were widely considered a nuisance. Free-range livestock practices were commonplace in colonial America, and roaming pigs routinely damaged crops and food stores of both colonists and Native Americans. Thus they were a source of much tension among colonists and even more so between colonists and Native Americans.

Today, free-range livestock practices are no longer used in the eastern United States, and all free-ranging pigs are considered wild pigs. Just

Today, wild pigs are a problem for many landowners and agricultural producers.



like the free-ranging domestic pigs of early America, today's wild pigs are a problem for many landowners and agricultural producers. In addition to damaging crops and livestock, wild pigs damage forests and are a threat to native wildlife and the environment. A conservative estimate of the cost of wild pig damage to agriculture and the environment in the United States is \$1.5 billion annually.



Alabama DCNR, Wildlife and Freshwater Fisheries Division, Chris Jaworowski



Arkansas Game and Fish Commission, Rachel Spaulding



Jay Cumbee, SCWDS



Jay Cumbee and Bill Hamrick, SCWDS

Because of the diseases they carry, wild pigs pose a real threat to commercial swine operations. Above left: a well-worn wild pig trail leading from a nearby swamp to the feed bins of a commercial swine operation. Above right: a wild pig harvested at night beneath the feed bins of the same commercial swine facility.

AGRICULTURAL DAMAGE

- Wild pigs consume and trample crops, and their rooting and wallowing behaviors further damage crop fields. Rooting and wallowing create holes and ruts that, if unnoticed, can damage farm equipment and pose a hazard to equipment operators.
- Wild pigs may at times prey on livestock, including newborn lambs, goats, and calves. Livestock predation usually occurs on calving or lambing grounds where wild pigs may be attracted by afterbirth and fetal tissue.

FOREST DAMAGE

- Hardwood mast (for example, acorns and hickory nuts) is a major food source for wild pigs. Consequently, regenerating hardwoods from seed can be difficult in areas with high wild pig populations. In areas where mast or fruit has already germinated, rooting



Eddie Parham

Pig rubbing and scent marking behavior damages trees and leaves them vulnerable to disease and parasites.



Mississippi State University Extension Service, Bill Hamrick

Pigs are attracted to longleaf pine seedlings because the root system is high in carbohydrates. Pigs chew the roots to extract the sap and spit out the masticated remains.

activities often dislodge and damage young seedlings

- Wild pigs can damage pine plantations and natural regeneration areas through direct consumption, rooting, and trampling. Longleaf pine (*Pinus palustris*) seedlings in particular are favored by wild pigs because the soft root system is high in carbohydrates.
- Wild pigs can damage both pine and hardwood trees by using them as scratching posts. Intense rubbing and damage to the bark layers can leave trees more vulnerable to harmful insects and pathogens (bacteria, fungi, and viruses).

THREATS TO NATIVE WILDLIFE

- Wild pigs compete for food and space with native wildlife species, especially game animals such as deer, turkey, and quail.
- Wild pigs can be significant predators of eggs and newly hatched young of ground-



Mississippi State University Extension Service, Bill Hamrick

Wild pigs are fierce competitors with native wildlife species for food resources such as hard mast.

nesting birds and sea turtles, small mammals, salamanders, frogs, crabs, mussels, and snakes. Though not considered a significant predator of white-tailed deer fawns, wild pigs do sometimes kill and eat newborns.

- Wild pig rooting, wallowing, and trampling damage native plant communities that provide habitat and food sources for native wildlife species.

ENVIRONMENTAL DAMAGE

- Rooting, wallowing, and trampling activities compact soils, which in turn disrupts water infiltration and nutrient cycling. Also, these soil disturbances contribute to the spread of invasive plant species, which typically favor disturbed areas and colonize them more quickly than many native plants.
- Wild pig activity in streams reduces water quality by increasing turbidity (excessive silt and particle suspension) and bacterial contamination. In time, turbidity and added



Westervelt Ecological Services, John McGuire

Wild pigs threaten ecologically sensitive communities such as the pine flatwoods of the Lower Coastal Plain of the southeastern U.S.



Eddie Parham

Wild pig activities in streams and other waterways can greatly diminish water quality.

contaminants affect a variety of native aquatic life, most notably fish, freshwater mussels, amphibians, and insect larvae. In some streams, feces from wild pigs have increased fecal coliform concentrations to levels exceeding human health standards.

- Destruction of vegetation in freshwater and brackish marshes not only reduces aquatic life and water quality but also affects ecosystem services, such as water filtration, flood control, and storm surge protection.

LEARN TO RECOGNIZE THE SIGNS

Sometimes landowners do not realize they have pigs on their property until they actually see a pig or until the damage is widespread. The earlier the presence of wild pigs is detected and control measures begun, the better. Some telltale signs that wild pigs have moved into an area include tracks, rooting, wallows, nests or beds, and tree and post rubs.



Alabama DCNR, Wildlife and Freshwater Fisheries Division, Chris Jaworowski

Pig rooting along levees, roadsides, and other thoroughfares can lead to costly infrastructure repair, equipment damage, and public safety concerns.

Wild pigs leave field signs that are unique and identifiable, making it relatively easy to determine whether wild pigs inhabit an area.



Mississippi State University Extension Service, Bill Hamrick

Rooting



Mississippi State University Extension Service, Bill Hamrick

Wallow



Mississippi State University Extension Service, Bill Hamrick

Wallow and tree rub



Mississippi State University Extension Service, Bill Hamrick

Utility pole rub



Mississippi State University Extension Service, Bill Hamrick

Wild pig nest



Mississippi State University Extension Service, Bill Hamrick

Wild pig track



Mississippi State University Extension Service, Bill Hamrick

Wild pig track



Mississippi State University Extension Service, Bill Hamrick

Deer track

WILD PIGS AND DISEASE

Wild pigs are known carriers of at least 45 different parasites (external and internal) and diseases (bacterial and viral) that pose a threat to livestock, pets, wildlife, and in some cases, human health. The risk of being infected by one of these diseases is real: in 2007, Florida health officials documented that 8 of 10 human cases of swine brucellosis were linked to wild pig hunting activities. Many of these diseases are transmitted through contact with bodily fluids and handling or ingestion of infected tissues. Diseases can also be transmitted indirectly through ticks or contaminated water sources. For more information on wild pig diseases, see Appendix I.

DISEASE PREVENTION

Follow these simple measures to avoid infection when handling or field dressing wild pigs:

- Wear latex or nitrile gloves; pathogens can enter the body through cuts on hands or torn cuticles.
- Avoid splashing body fluids into your eyes or mouth.
- Follow correct refrigeration, freezing, and cooking methods. Freezing to 0°F will render bacteria inactive but will not destroy them; once thawed, bacteria can again become active. You should not rely on home freezing to destroy *Trichina* and other parasites. Thorough cooking will destroy all parasites. Cook meat until internal juices run clear or until it has reached an internal temperature of 170°F.
- Wash your hands thoroughly after field dressing and processing meat, even if you wear gloves.

Wild pigs are known carriers of at least 45 different parasites and diseases.



USDA-Wildlife Services, Cal Betsill

Wearing latex or nitrile gloves will reduce your chances of potential disease risks associated with handling wild pigs.

- Thoroughly clean and disinfect work areas and tools used to dress and butcher wild pigs.
- Dispose of animal remains, used gloves, and other materials properly. Animal remains should not be left for scavengers, nor should they be fed to dogs. Depending upon your jurisdiction, several methods of appropriate disposal may be considered. Check with your local health department or state wildlife agency.



Sherman "Skip" Jack
*Professor of Veterinary
 Pathology*

*Mississippi State
 University, College of
 Veterinary Medicine*

DISEASE IMPACTS OF WILD PIGS

Diseases of wild pigs affect humans and other animals in several ways. First, there are diseases that are transmissible to humans, called zoonotic diseases. Then there are diseases that might impact livestock and pets (for example, swine, cattle, and dogs). A third group of diseases are foreign animal diseases (FADs), those that have never been present in North America or those that were present at one time but have been eradicated during the last 100 years. (Examples are foot-and-mouth disease and hog cholera, or classical swine fever.) While not a direct threat to human health, FADs would have overwhelming economic impact if introduced — or reintroduced — and perhaps never again could be eradicated from our continent because of the continued expansion of wild pig ranges.

Foreign Animal Diseases & Pseudorabies

Foreign animal diseases include a number of conditions that have never been identified in North America or have been eradicated during the past century. Some of these diseases affect only swine (for example, hog cholera, or classical swine fever, and African swine fever), but others affect multiple species such as foot-and-mouth disease, which can affect cloven-hooved animals like cattle, deer, and elk. Both hog cholera and foot-and-mouth disease were eradicated from the United States during the previous century (hog cholera during the 1970s, foot-and-mouth disease in the early 1900s). However, eradication occurred before wild pigs were found in most of the lower 48 states, and even

then the cost was in the billions of dollars. Thus, reintroduction of those diseases today would have a greater host population in which to spread and would be much more costly, if not impossible, to eradicate again.

Pseudorabies virus (PRV), while not foreign, is another disease with implications for nonswine animals such as cattle, sheep, and dogs. This disease is a herpes virus and is not related to rabies. Some symptoms of the disease may resemble rabies, thus the term *pseudorabies*. It sometimes kills pigs but is routinely fatal in nonswine species that become infected either through direct contact or ingestion of tissues from PRV-positive wild pigs. Pseudorabies is a reportable disease and may restrict transporting animals (even uninfected ones) across state lines. Thus the economic impact may extend well beyond affected animals or affected premises. See Appendix I for more information on common diseases among wild pigs.



Bacteria (*Staphylococcus*)

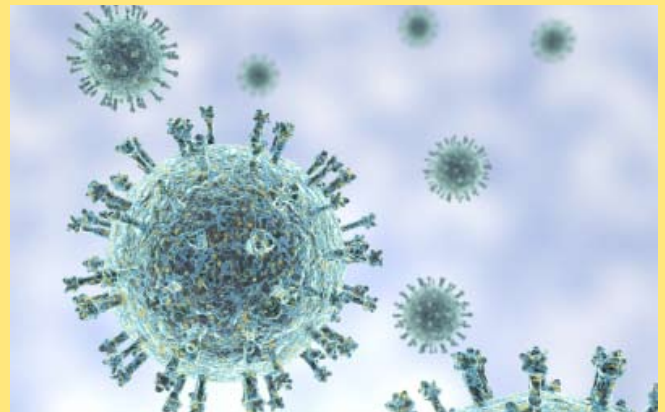

Virus (Swine influenza)

Wild pigs are known carriers of bacterial and viral diseases that are a threat to livestock, wildlife, pets, and in some cases human health.

MANAGEMENT

Wild pig populations can be managed by lethal or nonlethal methods. Nonlethal methods include installing fencing to exclude pigs, using guard animals to protect livestock, and vaccinating animals to prevent disease spread. Although in some situations nonlethal methods are appropriate and effective, in many cases they are not a good option, either because they do not work well or are too expensive. Therefore, lethal methods are often the most practical and widely used. They include trapping, shooting, and hunting with dogs. Currently, there are no toxicants registered for use on wild pigs in the United States, so poisoning is not an option.

Hunting and trapping regulations vary by state. Be sure to check the hunting and trapping regulations specific to your area or contact your local conservation officer before beginning any wild pig trapping and removal program in an area.

TRAPPING WILD PIGS

Trapping is the most efficient means for removing wild pigs because it is a continuous activity requiring far less time and effort than other methods such as hunting. Successful pig trapping hinges upon several key components:

- locating high-use areas for potential trap sites
- prebaiting and baiting
- effective trap design and size
- effective trap door design
- patience

Currently, there are no toxicants registered for use on wild pigs in the United States.



Alabama DCNR, Wildlife and Freshwater Fisheries Division, Chris Jaworowski



Wild pigs do not acknowledge boundaries and land lines. Therefore, a cooperative trapping effort with adjoining landowners will prove more successful than conducting a trapping program on your own.

Scouting the Trap Location

Set traps in areas where wild pig activity is the greatest. Wild pigs often spend much of their time in shaded areas of thick cover close to a water source. Therefore, river and creek bottoms and other low-lying areas should be scouted first for activity. Although this point may seem obvious, many would-be trappers make the mistake of selecting areas where they think pigs should be and not where the pigs actually are.

Once you have located an area with abundant pig sign, do not immediately set up your trap. Instead, establish a baited “scouting site” to determine whether or not wild pigs are actively using the area. You can help attract wild pigs to your bait site by topping the bait with sorghum molasses, a similar sweet smelling syrup, or commercial bait topper. Another option is to use fermented corn. Revisit the site daily to determine if pigs have found the bait.

Depending on the size of your property and the distance between locations with recent pig activity, you may want to establish several of these scouting sites to determine which locations pigs are actively using. Once you have identified an active location, set up a trap and begin prebaiting. Wherever possible, establish your trap site on fairly level ground and in a shaded area upwind of bedding and loafing areas. Ensuring vehicle access close to the trap site will save time and labor in constructing, baiting, and checking the trap, and also in removing pig carcasses from the trap.

Prebaiting

Prebaiting is probably the most important component to successful pig trapping and perhaps the most overlooked by trappers. The goal of prebaiting is to attract pigs to the trap site, and more important, to get all of the pigs in a sounder — or family group — conditioned to entering and leaving the trap unharmed.

Usually, 1 to 2 weeks of prebaiting is necessary before the entire sounder will enter

the trap. However, 2 weeks may pass and some pigs still may not have entered the trap. Some pigs in a sounder initially do not feel comfortable entering a trap and will stay outside while others readily enter and feed on the bait. This trap-shyness is especially true for older pigs and pigs that have been previously trapped and released into the wild. Therefore, it is important to be patient and allow all of the pigs to become conditioned to safely entering and leaving the trap before it is set. Pigs are intelligent animals, and if the trap is set too soon, members of the sounder that you do not catch will have become educated and will be much more difficult, if not impossible, to capture later.



Trail cameras are very useful for conducting round-the-clock surveillance of prebaited traps and take the guesswork out of when to set the trap. See the section entitled “Using Remote-Sensing Cameras to Enhance Wild Pig Trapping Efficiency.”



Jay Cumbee and Bill Hamrick, SCWDS

Prebaiting a trap with corn and sweet potatoes.

When dealing with trap-shy pigs, you may need to remove the door from the trap and create a larger opening until they become conditioned to regularly entering and leaving the trap. Also, a larger trap may appear less confining to trap-shy pigs.



During the prebaiting period, tie the trap door securely open to prevent premature captures of wild pigs and to allow them continual access to the bait. Place the bait on the ground inside the trap and scatter it on the ground in areas immediately surrounding the trap. You may place a larger amount of bait (about 1 to 2 gallons if using shelled corn) just inside the trap entrance to entice pigs to enter.

Once pigs are “on the bait,” it is important to maintain a constant supply of bait in and around the trap so pigs will have something to eat each time they visit the site. The use of a spin-cast automatic feeder suspended over the trap during the prebaiting period will reduce the amount of time and effort needed to keep the trap baited and will minimize human disturbance to the area.

Choosing a Bait

A wide variety of items such as shelled corn (dry or fermented) and other grains, table scraps, commercial scents or attractants, molasses, or a combination of these items may be used as bait for trapping wild pigs. It is important to note there is no best bait to use. Wild pigs in some areas may prefer one type of bait over another. However, it is usually best to begin baiting traps with whole-kernel dried corn (shelled or on the cob). It is readily available at local feed and seed stores, is

easy to work with (there is no excessive odor or mess as with fermented corn), and more often than not it does a good job of attracting wild pigs. If it becomes clear that pigs are visiting your trap but not readily consuming corn, experiment with other types of bait or attractants.



Game laws regarding the use of bait vary between states. Before you prebait or bait any pigs or pig traps, be sure to check the baiting regulations specific to the state in which you will be conducting these activities.

Baiting and Setting the Trap

Once you observe or are confident that all pigs in a sounder are consistently entering the trap, it is time to make a set. The placement of bait within the trap is a very important detail of pig trapping. Do not bait heavily around the trigger mechanism. All too often, traps are baited heavily around the trigger mechanism and only a few individuals in the sounder are captured, namely, those that were first to enter the trap. Instead, bait heavily along the inside of the trap opposite the side where the trigger is located and place only a small amount of bait around the trigger mechanism.

The rationale behind this technique is that pigs will enter the trap and naturally gravitate toward the larger pile of bait. As more and more pigs enter the trap to feed, one or several pigs will be pushed aside from the larger bait pile and switch to feeding on the bait around the trigger mechanism, eventually springing the trap. Using this strategy can increase trapping success rates from 1 or 2 animals to 10 or more.

After several weeks of prebaiting, if you continue to observe a pig or pigs that just will not enter the trap, you will need to decide whether or not to

go ahead and set the trap. Once you have set the trap, be sure to check it daily, preferably in early to midmorning. See Appendix II for illustrations of baiting strategies.

Types of Pig Traps

There are three main types of wild pig traps: box traps, cage traps, and corral traps. Traps may be constructed from steel or wood and typically are rectangular or round. Though some experienced pig trappers have individual preferences, a trap of adequate size in any of those shapes is effective in capturing pigs if the trapping process is properly executed.

Trap efficiency is important, so keep in mind that catch size is a limiting factor with certain types of traps. Factors to consider when selecting

the type of pig trap that will best meet your needs are

- sounder size
- affordability
- weight and portability
- presence and numbers of nontarget species such as deer or black bear



The terms “box trap” and “cage trap” often are used interchangeably when referring to any square or rectangular trap. However, in this publication they are classified as two different trap types.

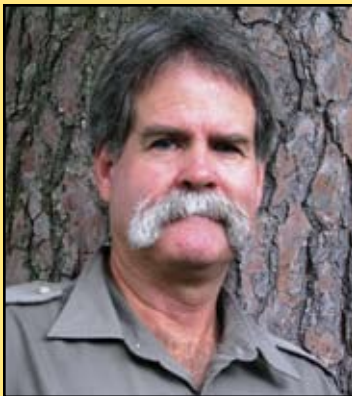

Billy Higginbotham
*Professor and Extension
 Wildlife & Fisheries
 Specialist*
*Texas AgriLife
 Extension Service*

USING REMOTE-SENSING CAMERAS TO ENHANCE WILD PIG TRAPPING EFFICIENCY

For those areas where wild pigs have not had negative encounters with humans or where little or no trapping has been done, you can get away with a lot. However, try those same techniques with pigs that have been hunted, dogged, and — heaven forbid, trapped and released — and you’re dealing with what amounts to a completely different animal. So how can landowners stack the odds in their favor when dealing with this

super intelligent animal? Using a remote-sensing camera throughout the prebaiting period not only eases the task at hand but also provides helpful information that will increase your pig trapping success.

You can make on-site observations of bait consumption and check for other signs such as tracks, but having a camera recording around the clock to monitor wild pig response to prebaiting is a big help. Trapping wild pigs is a process, not an event, and in addition to confirming pig response to prebaiting efforts, the camera will also reveal the approximate number of pigs in the sounder. This information speaks volumes as to the size of trap that will be needed to do the job. Also, most cameras record the dates and times of events, and it’s sometimes helpful to know just when those visits occur.

The question I’m always asked about cameras is whether models with infrared features are necessary to avoid spooking the pigs with a flash. In my experience, the flash is not a deterrent on the larger traps that I employ. However, on a

smaller trap, the camera should be positioned a comfortable distance away, yet close enough to be triggered reliably and capture the action.

Because a picture is worth a thousand words, the camera should continue to record during the actual trapping phase. Were you successful in capturing the entire sounder? If not, were some pigs still outside when the gate was tripped, or were they absent that particular night? Did any pigs escape from the trap? If so, how did they do it? Photographs can provide good information that will help you to be a more effective pig trapper. Using remote-sensing cameras set in the right location, plus patience on your part, make for a successful pig trapping formula.



Trail cameras are the best tool for monitoring wild pig activity during the trapping process.

Box Traps

Box traps are rectangular or square structures made of wood fence panels constructed from 2-by-4-inch and 1-by-4-inch or 1-by-6-inch boards. The most common box trap design is 4 feet wide, 8 feet long, and 5 feet high with no fixed top or bottom. (A top is not necessary because the 5-foot-high side panels prevent pigs from climbing out).

The trap is usually equipped with a single-catch wooden drop door, but it also can be equipped with a multicatch trap door, such as the saloon-style door. Box traps are heavy enough that pigs usually are unable to root under the sides and use their head to lift the trap and escape. However, it is still best to secure box traps by driving a steel T-post into the ground at each corner and fastening the trap sides to the T-posts with wire.

The box trap can be transported in panels and assembled on location using 3-inch exterior decking screws (nails are not recommended). A trip wire or root stick is the best trigger mechanism to use with box traps.



Mississippi State University Extension Service, Bill Hamrick

A 4' x 8' x 5' box trap fitted with a guillotine or drop-style wooden door.

Cage Traps

Cage traps are constructed from heavy-gauge wire livestock panels welded to a steel angle iron or square tubing frame. The most common cage trap design is a rectangular enclosure ranging in size from 4 feet high, 6 feet long, and 4 feet wide to 5 feet high, 12 feet long, and 4 feet wide.

A more recent design is a circular cage trap with wire livestock panels welded to a round steel frame (similar to livestock hay rings). The advantage of this design is its portability; it can be rolled onto a trailer or rolled along the ground. Another design is similar to the box trap and is made up of wire livestock panels welded to individual steel frames and fastened together with pins or bolts.

Commercially available cage traps often have both a top (overhead) and bottom (floor) panel and are equipped with a spring-loaded, single-catch or multicatch trap door at one end of the cage.

Cage traps less than 5 feet tall should include a top panel to prevent pigs from escaping over the sides. Bottom or floor panels are not necessary for well-built cage traps. In fact, many experienced pig trappers recommend not using floor panels. Their reasoning is that most pigs do not like the feel of the wire panel underfoot and will balk at fully entering the trap.

To prevent large pigs caught in this type of trap from lifting the trap and escaping underneath the side panels, wire the trap to T-posts driven into the ground at each corner.

Corral Traps

Corral traps are the most effective type of trap for catching large groups of pigs. Though corral traps can vary in shape, many experienced pig trappers recommend a circular trap because it prevents captured pigs from piling into corners and escaping over the top.

Corral traps can be constructed using heavy-gauge wire or U-bolts to fasten 16-foot by 5-foot

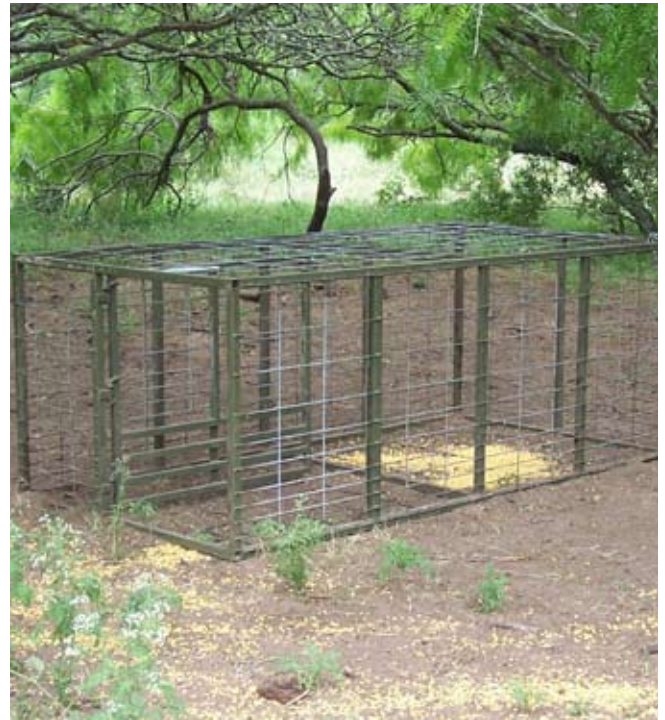

Texas A&M-Kingsville, Randy DeYoung

Cage trap.



Randy Kelley

Round cage trap.



Alabama DCNR, Wildlife and Freshwater Fisheries Division, Chris Jaworowski

Corral trap with a guillotine or drop-style wooden door.



Rex Allen Jones, Natural Resources Media & Nature Videography

Corral trap with a rooster-style trap door.

welded wire livestock panels to 6½-foot steel T-posts. Corral traps are quick and easy to build, and just three or four 16-foot by 5-foot panels will produce a trap of sufficient size for catching most sounder groups. You can easily expand the trap's size by adding more livestock panels.

To build a circular corral trap, begin by overlapping the livestock panel ends 1 foot and securing the adjoining ends using 5/8-inch cable clamps or heavy-gauge wire. Be sure to leave two panel ends free to accommodate the trap door. (Either a single-catch or multicatch trap door can be used.) Next, shape the corral by pushing or pulling the joined panels in or out as you work them into a circle. Once the corral is fashioned to your liking, set the trap door in place and drive T-posts into the ground immediately next to and on each side of the trap door. Attach the loose panel ends securely to both the trap door frame and T-posts with heavy-gauge wire.

If using a trap door that does not extend to a height of 5 feet, you will need to account for the height difference to prevent pigs from jumping over the trap door. There are two ways to do this:

- If the trap door is positioned between the ends of two livestock panels as described above, use a piece of livestock panel or other heavy-duty mesh wire to cover the opening above the trap door.
- Simply cut an opening for the trap door in the middle of one of the 16-foot livestock panels. Be sure to install T-posts on each side of the trap door for additional support and use heavy-gauge wire to attach the door to the livestock panel and T-posts. This will prevent wild pigs from jumping over the trap door.

With the trap door securely in place, finish the trap by working your way around the corral and driving a T-post in the ground about every 4 feet on the outside of the panels (at the overlapped ends and the middle of each panel). Use heavy-gauge wire to fasten the livestock

panels to the T-posts every 1 foot beginning at ground level (five per T-post). You also can use U-bolts as fasteners (three to four per T-post). For more information on constructing a round corral trap see Appendix III.

Livestock panels used in constructing wild pig traps should be of at least 4-gauge size and no less than 5 feet high. Though it is not impossible, only the rarest of pigs can jump a 5-foot-tall panel. A mesh size of 4 inches square or smaller will prevent small pigs from escaping through the panels.



Trap Door Designs

Single-Catch Trap Doors

Guillotine or drop-style doors are called “single-catch” doors because once the trap has sprung (that is, the door has closed) no more animals can enter the trap until it is manually reset. Therefore, it is extremely important that the trap be strategically baited to insure that most if not all of the pigs in a sounder have entered the trap before the door is released.

Single-catch doors are relatively inexpensive and can be easily constructed using 2-inch-by-4-inch and 2-inch-by-2-inch lumber and ¾-inch thick plywood. (See door specifications and construction design in Appendix III.) With proper prebaiting and remote sensing camera footage, single-catch doors can be just as effective at catching pigs as other types of trap doors.

Pros and Cons of Trap Types

Type of Trap	Pros	Cons
Box Trap	<ul style="list-style-type: none"> • easy to construct • cheaper than commercial steel traps • requires less space for transport and storage • quick setup with wood screws and a cordless drill 	<ul style="list-style-type: none"> • catch size/trapping effort limited • wood panels appear more confining than wire panels • wood requires more long-term maintenance than wire panels • not conducive to one-person transport and setup
Cage Trap	<ul style="list-style-type: none"> • wire panels appear more open and less confining to pigs • easy one-person transport and setup 	<ul style="list-style-type: none"> • catch size/trapping effort limited • overhead panels prevent most nontarget species from escaping
Corral Trap	<ul style="list-style-type: none"> • trap size easily adjusted for larger sounders • open top allows for escape of nontarget species • trap appearance and open top may appear less confining to pigs 	<ul style="list-style-type: none"> • requires more setup time than cage or box traps • livestock panels may need to be cut in half for transport • tree roots in wooded areas can pose a problem for driving and pulling T-posts

There are many different trap door designs. The type of door you use depends on budget and ease of transport.



Alabama DCNR, Wildlife and Freshwater Fisheries Division, Chris Jaworowski



Alabama DCNR, Wildlife and Freshwater Fisheries Division, Chris Jaworowski

Guillotine or drop-style trap doors are commonly constructed from lumber but can also be constructed from steel.



Mississippi State University Extension Service, Bill Hamrick



Mississippi State University Extension Service, Bill Hamrick

Once triggered and shut, the saloon or butterfly-style trap door allows pigs outside the trap to push in and enter the trap, but they cannot push out and exit the trap. If using a trap door less than 5 feet in height, use a piece of steel mesh panel to account for the difference in space between the top of the door and the top of the trap sides.

Depending on the trigger mechanism used, nontarget species such as raccoons can reduce success rates with single-catch trap doors. See the section entitled “Trip Wires Versus Root Sticks.”



Multicatch Trap Doors

Saloon and root door designs allow additional animals to enter the trap once it has been sprung. There are many variations in terms of structural design and materials used for both saloon and root doors; however, doors are usually made of steel — either angle iron or steel tubing (square or circular) or a combination of the two. Saloon-style doors are equipped with heavy springs that quickly shut the door once the trap has sprung. Rooting-style trap doors simply fall shut. Both types of doors are equally effective, and rarely will a pig be able to run out of the trap before the door closes. See Appendix III for illustrations of multicatch doors.

When first setting the saloon-style trap door, prop the doors open with the triggering mechanism and drive a stake into the ground behind both doors. This technique prevents pigs that make their turn too soon when entering the trap from pushing one door farther open and springing the trap.



Mississippi State University Extension Service, Bill Hamrick

Placement of stakes behind each door panel on the inside of the trap.



Mississippi State University Extension Service, Bill Hamrick

Rooster-style trap doors can be constructed from either steel or aluminum. The door contains three separate panels. Once the trap has tripped (1) three separate panels make it easier for pigs to push open versus one solid panel and (2) it reduces the chance for already captured pigs to escape while other pigs enter.

Trigger Mechanisms

One of two primary trigger mechanisms is commonly used when trapping wild pigs: the root stick and the trip wire. Both trigger mechanisms are effective, and either type can be used with any trap door. However, when using a multicatch trap door, a trip wire works best. The action needed to pull the prop from the saloon-style door or to release the door panels on the root door work much more smoothly and reliably with the trip wire.

Root Sticks

The root stick is a simple trigger mechanism consisting of two sections of rebar (reinforcing bar) or two sticks called holding stakes driven into the ground at a 45-degree or 60-degree angle (with the ends pointing away from the trap door). A length of rope or cord is attached at one end to the drop door and at the other end to the middle of a strong stick or piece of scrap lumber, called the root stick. The door is held open by wedging the root stick behind the holding stakes. Bait is placed around and on top of the root stick, and the trap is sprung when feeding and rooting pigs push the root stick out from behind the holding stakes.

Trip Wires

The trip wire is a line or wire strung across one corner or the rear section of the trap, run around one side of the trap, and attached to a triggering device (pin, hook, or prop stick) on the trap door. Once sufficient pressure is exerted on the line or wire, the trigger device releases the door and the trap is sprung. The amount of pressure required to spring the trap can be adjusted by tightening or loosening the trip wire.

When stringing the trip wire from the trap door to the rear section of the trap (the point at which it will change direction and cross the width of the trap), position the line or wire high enough so that the backs and heads of adult pigs



Alabama DCNR, Wildlife and Freshwater Fisheries Division, Chris Jaworowski

Root stick.

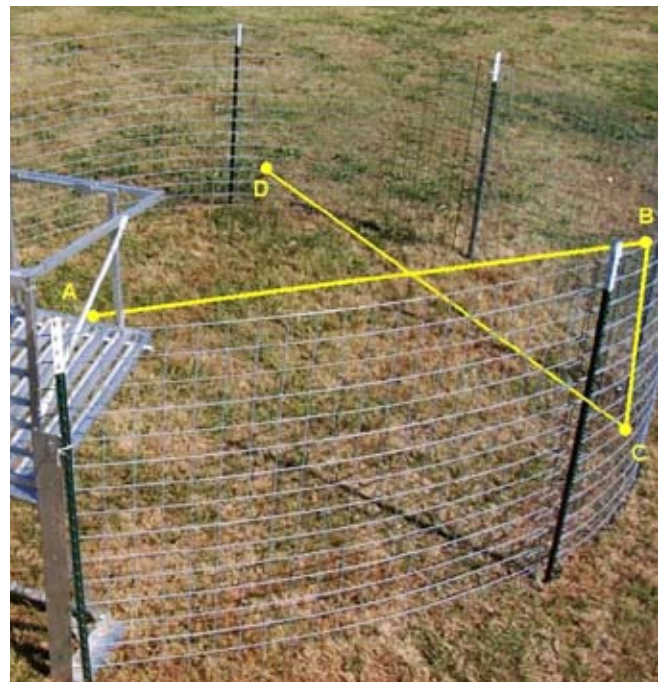

Mississippi State University Extension Service, Bill Hamrick

Trip wire.

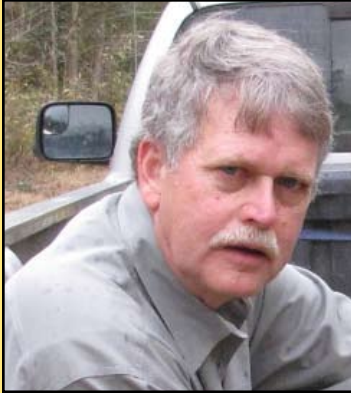

Carl Betsill
*North Carolina
 Wildlife Disease
 Biologist, Retired*
 USDA/APHIS/Wildlife
 Services

TRIP WIRES VERSUS ROOT STICKS

When I first began trapping wild pigs I was a firm believer in using a root stick to trigger the trap door. My theory at the time was that pigs are very aggressive eaters, and a root stick will provide time for all the pigs to enter the trap before the trigger mechanism is tripped and the door drops. Observing traps with trail cameras has caused me to reevaluate my thinking.

I was surprised to find that pigs were entering my trap, eating a couple of bites of corn from

around the root stick, and leaving. With leaf litter on the ground, there was often no sign that pigs had been there. When the root stick did work, it was not always from rooting but was simply triggered by chance — the pigs hit the rope with their backs. The trail camera video often revealed pigs entering and leaving over a period of up to two hours before triggering the trap door.

For this reason I now favor the trip wire. It can be set high enough to avoid small pigs, raccoons, and opossums but still low enough to be tripped by shoat and adult pigs. With proper bait placement, multiple captures are still possible.

While I have not broken my record of 19 pigs in one trap with a root stick, I commonly get 6 to 9 pigs even with the trip wire. I still use the root stick, especially in areas where I'm plagued with deer visits, but after observing that pigs can sometimes be "dainty" eaters, I certainly don't use it as much.

cannot disturb it. To avoid the trap being sprung early by nontarget species, such as raccoons and opossums, suspend the trip wire across the rear section of the trap about 2 feet above the ground. Suspending the trip wire at this height will also help reduce the chances of younger and smaller pigs springing the trap too soon. See Appendix III for an illustration of a trip wire.

SNARING WILD PIGS

The use of steel cable snares to capture wild pigs can be very effective. However, they pose a greater risk than other methods for capturing nontarget wildlife species (such as bear, deer, and turkey) as well as domestic animals (such as calves, sheep, goats, and dogs). For this reason it is illegal to use snares in some states. In those

states where snares are legal, natural resource agencies often discourage their use except when used by a trapping professional.

EUTHANIZING WILD PIGS

Although pigs are a nuisance or pest species, they are wild animals and appropriate measures should be taken to minimize stress to the animal and insure that they are dispatched humanely. Pigs can be easily dispatched using a firearm chambered for .22 long rifle or larger calibers fired precisely into the brain cavity. The brain shot will insure a quick, humane death while minimizing the amount of blood left in the trap. A shot placed about 2 to 3 inches above an imaginary line directly between the eyes, or at the midpoint of an imaginary line between the eye and ear, will effectively penetrate

the brain cavity. Be careful not to shoot pigs directly between the eyes as this area is the beginning of the nasal cavity.

Always observe proper firearm handling and safety precautions.



If euthanizing wild pigs with a rifle, do not insert the rifle barrel through the side panels in an effort to avoid accidentally shooting the trap. Pigs commonly will charge and ram into the side of the trap trying to find a way out. If a pig happens to charge just before you shoot, it may strike the barrel of the firearm, with you on the other end of

it. This could cause you or someone else a serious injury. Instead, either shoot through the fence or shoot down into the trap from an elevated position (for example, while standing on an ATV or in the bed of a pickup truck). Always observe proper firearm handling and safety precautions.



Adult wild pigs are quite strong and can be aggressive, so exercise caution when approaching a trap. Approach the trap slowly and whenever possible from downwind to minimize animal excitement and stress. This strategy will also minimize trap damage.



Chris Jaworowski
Wildlife Biologist
Alabama Department
of Conservation and
Natural Resources

NIGHTTIME OPS FOR WILD PIG CONTROL

Multifaceted wild pig control programs often include trapping, shooting, hunting with dogs, and even advanced techniques such as aerial gunning from helicopters. Though all of these options can reduce pig populations, they also can lead to increased nocturnal movement of wild pigs, thus reducing removal success. To maintain pressure on wild pig populations, landowners and natural

resource managers often incorporate nighttime control operations to continue their “war on pigs.” Nighttime options include the use of a rifle and spotlight, night vision optics, and thermal imagery equipment.

There is a common misconception that harvesting pigs at night is easy, but this could not be further from the truth. Hunting pigs at night with rifle and spotlight is difficult, and success rates often are very low. Unlike animals such as deer, pigs lack the reflective layer in the eye that produces “eye shine.” As a result, this method often works best when conducted in open habitat types such as pastures, fields of low-growing crops, and roadsides. Spotlights with 2 to 3 million candlepower will easily illuminate pigs out to 100 yards in these open habitats. Also, employing this method during times of bright moonlight will increase your ability to detect and approach sounders of pigs before illuminating them for shooting.

SHOOTING AND HUNTING WILD PIGS

In some cases, shooting and hunting have proven effective for controlling wild pigs, but these methods require a significant amount of time and effort, and it is rare for them to be effective in substantially reducing pig numbers. Regardless of whether you are shooting at night, shooting over bait, or still hunting, not only must you be on site when the pigs are there, but it is also very difficult, if not impossible, to shoot all of the pigs you may encounter. Hunting with dogs can be effective in some situations, but this method is also ineffective in removing large numbers of pigs. Instead, shooting and hunting are best used as complements to a rigorous trapping program and not as the primary means of removal. For more information on shooting and hunting wild pigs see the sections entitled “Nighttime Ops for Wild Pig Control” and “Hunting Pigs with Dogs.”

NONTARGET SPECIES

When planning and implementing a wild pig control program, always consider any potential negative effects on nontarget species. Bait items such as corn, other grains, and sweet potatoes attract not only wild pigs, but also black bear, deer, and turkey. Therefore, large nontarget species may be accidentally captured in pig traps. Some state trapping laws require that any covered pig traps have an opening in the top sufficient to allow large nontarget species to escape. Depending upon opening size, black bears may escape much easier than deer. For this reason, natural resource professionals often recommend using open-topped pig traps, especially in areas with high potential for incidental capture of nontarget species. If traps with corners are used, cover only the corner portions of the trap to reduce the opportunity

Advances in night vision equipment have increased success rates for nighttime pig control efforts. Whereas earlier night vision optics had poor resolution and clarity, the latest models available to the public produce clearer and crisper images that make it possible to detect pigs as far out as several hundred yards. Working in total darkness, you can maneuver quietly, detect and identify pigs quickly, and then set up and take close shots. Also, because you can get much closer to pigs, night vision optics increases your chances at multiple shots from effective ranges. However, the cost of quality products is a limiting factor for most private landowners.

Thermal imaging equipment is another option available for nighttime pig control. Thermal instruments detect heat given off by all objects in nature and produce a gray-scale visual image of the heat differences. Animals appear against a gray background as if illuminated by a white light. This technology enables users to detect warm-

blooded animals at distances greater than 1/2 mile away. Because thermal imaging equipment detects the heat of all objects in nature, it does not work well in areas with a heavy forest understory or midstory. It performs best when used in open habitat types like pastures, crop fields, and roadsides.

Hunting pigs at night is not legal in all states. Be sure to check the state hunting and trapping regulations specific to the area or contact your local conservation officer.

Like night vision equipment, thermal imaging equipment is not affordable for most private landowners.

Despite ongoing control programs, wild pig populations and damage estimates continue to grow annually in the United States. Because pigs are such intelligent and highly adaptive animals, the more tools available to combat this nonnative species, the better.

for pigs to climb and escape while leaving a large opening for nontarget animals to exit the trap.

Always make positive target identification. Always be aware of your position in relation to hunting partners, public roads, buildings, and residential areas.



Hunting and shooting wild pigs also pose potential problems for nontarget species. During low-light conditions (dawn and dusk) or in dense cover, animals such as black bear, dark-colored livestock, and dogs can be easily mistaken for wild pigs. Regardless of time of day, hunters must always make positive target identification. Always be aware of your position in relation to hunting partners, public roads, buildings, and residential areas.



Mississippi Dept. of Wildlife, Fisheries & Parks, Brad Young

Fully enclosed cage traps do not allow for the escape of nontarget species such as this Louisiana black bear, a federally protected species.



The American black bear is a protected species and cannot be legally harvested in many states in the Southeast. In states where black bear harvest is legal, harvests are subject to seasonal regulations. The Louisiana black bear, a subspecies of the American black bear, is federally protected and cannot be legally harvested at any time.



Scott Alls

*USDA/APHIS/Wildlife
Services*

HUNTING PIGS WITH DOGS

The tradition of hunting pigs with dogs can be traced back to early America when settlers and farmers commonly free-ranged their livestock. In order to distinguish ownership of their livestock, individuals or families would apply a unique mark — usually a series of splits or notches — to the ear or ears of individual animals. Free-ranging pigs usually were rounded up and “marked” twice per year, and the use of dogs to locate, bay, and catch these pigs made the task much easier.

Today, pig hunting with dogs has evolved into a highly popular form of sport hunting. Although this method of hunting is sometimes controversial, it serves as a valuable tool when trying to remove pigs in areas where intense shooting and trapping pressure have driven pigs to become more nocturnal in their activity patterns. Dogs can be used to trail these skittish pigs to their bedding areas. In addition, dog hunting pressure often will

drive pigs from an area for extended time periods. Although this is only a temporary solution, it does buy some time for planting crops and building exclusion fences.

Pig-hunting dogs are usually grouped into one of three categories: open trailing dogs, silent dogs, and catch dogs. Open trailing dogs bark while tracking or chasing pigs, whereas silent dogs do not, hence their names. Silent dogs often are more popular among hunters because they catch more pigs and races seem to be shorter, thus covering less ground and decreasing the chances of getting onto property where dogs are not welcome. Once the open trailing dogs or silent dogs have a pig at bay, the catch dog is released to move in and hold the pig — usually by the ear — until the hunters can arrive and dispatch the animal.

Though trapping is the most efficient means of removing pigs from an area, dog hunting is the most effective means of removing trap-shy or “educated” pigs that have altered their activity patterns based on previous experience with traps. However, landowners should exercise caution when employing the services of dog hunters. Be aware that some hunters catch and tie pigs and relocate them to other areas, thus creating future hunting opportunities. Therefore, be sure to ask potential hunters for references and come to an agreement that any and all pigs captured will be dispatched on site.

WHERE DO WE GO FROM HERE?

Wild pigs will continue to be a management challenge for landowners and natural resource professionals for years to come. Although wild pig damage is a relatively new phenomenon in many areas of the United States, other parts of the world have been dealing with the problem of wild pigs for hundreds of years. Expanding pig populations are a global wildlife management challenge.

Many researchers agree that the most promising control techniques for the future include the use of toxicants (poisons) and contraceptives (birth control methods). Wildlife scientists have developed chemicals that will humanely kill pigs and are currently developing species-specific oral contraceptives to suppress reproduction. The problem, however, has been the development of a bait delivery system that will target only pigs and not other wildlife. Unfortunately, development of such a delivery system is a challenge that will likely take many years to overcome.

In the meantime, the best course of action for landowners, farmers, and natural resource professionals is to

- educate the general public, policymakers, and pig hunters about the negative impacts of wild pigs and the threats they pose to agriculture, native plant and animal

Wild pigs will continue to be a management challenge for years to come.



communities, the environment, and human health

- promote cooperatives among adjoining landowners to reduce pig populations on larger blocks of land
- increase state and national efforts to collect and report more accurate quantitative data on acreage and economic impacts of pig damage
- petition policy makers and legislative committees to strengthen current laws, restrictions, and penalties regarding translocation of wild pigs and hold owners of fenced hunting preserves liable for escaped pigs

Until society recognizes wild pigs as a serious economic and ecological threat, and until legislation is passed that removes incentives to relocate these animals, this problem will not go away.

APPENDIX I

ZOONOTIC DISEASES

Bacteria

Leptospirosis: The most common zoonotic disease worldwide, Leptospirosis can infect virtually all warm-blooded animals (including humans). The disease commonly affects the liver, kidney, and reproductive tract and is thus spread through urine, birthing fluids, and blood. The bacterium can survive in warm water for extended periods. Leptospirosis is usually mild, producing flu-like fever, chills, aches, pains, and jaundice. In humans, Leptospirosis usually responds to antibiotics but if undiagnosed and untreated can result in death.

Brucellosis: There are multiple species of this bacterium that are somewhat restricted to particular animal species, but in most species it involves the male and female reproductive system (typically causing testicular inflammation, embryonic death, or abortion and infertility). *Brucella* is capable of crossing mucous membranes and intact skin. Brucellosis infections in humans most often occur from handling infected tissues without protective hand wear. In humans, the disease produces a fever that comes and goes (undulant fever) and thus may be difficult to diagnose. Like Leptospirosis, it usually responds to long-term antibiotic therapy in humans and animals.

Salmonellosis: Many swine can harbor *Salmonella* without showing clinical signs. This bacterium is usually found in the lower gastrointestinal (GI) tract and can produce infection through fecal contamination of meat during processing or by ingestion of improperly handled or poorly stored meat products. In humans, Salmonellosis begins with diarrhea and vomiting and if untreated may progress to blood poisoning, dehydration,

and death. Like other bacteria, this disease can respond to proper antibiotic therapy.

Viruses

Rabies: This disease is usually transmitted only through the bite of a rabid animal and affects primarily the nervous system. Rabid animals usually exhibit abnormal behavior, and the disease is ultimately fatal in most hosts. Rabies is a reportable disease and can only be confirmed by an approved public health laboratory.

Influenza viruses: Swine can serve as a reservoir and amplifying host for influenza viruses. Signs of influenza in humans and animals can range from extremely mild, with some systemic or respiratory signs (such as cough, aches, and chills) to an overwhelming multisystemic and occasionally fatal disease. However, prevalence of these diseases is thought to be low, and direct transmission to humans has not been demonstrated.

Parasites

Trichinella: This round worm localizes within the muscles of humans and swine and also cycles through wild rodents. When ingested in undercooked meat, *Trichinella* can localize in muscle tissue and produce intense pain in humans.

Giardia* and *Cryptosporidium: These protozoan parasites affect many animals. They localize in the lower GI tract and produce cramps and diarrhea that may lead to dehydration and death if untreated. These agents are shed in the feces of the primary host and gain entrance to the secondary host through water contaminated with fecal matter or improperly handled food products. Each of these parasites is treatable upon proper diagnosis.

APPENDIX II

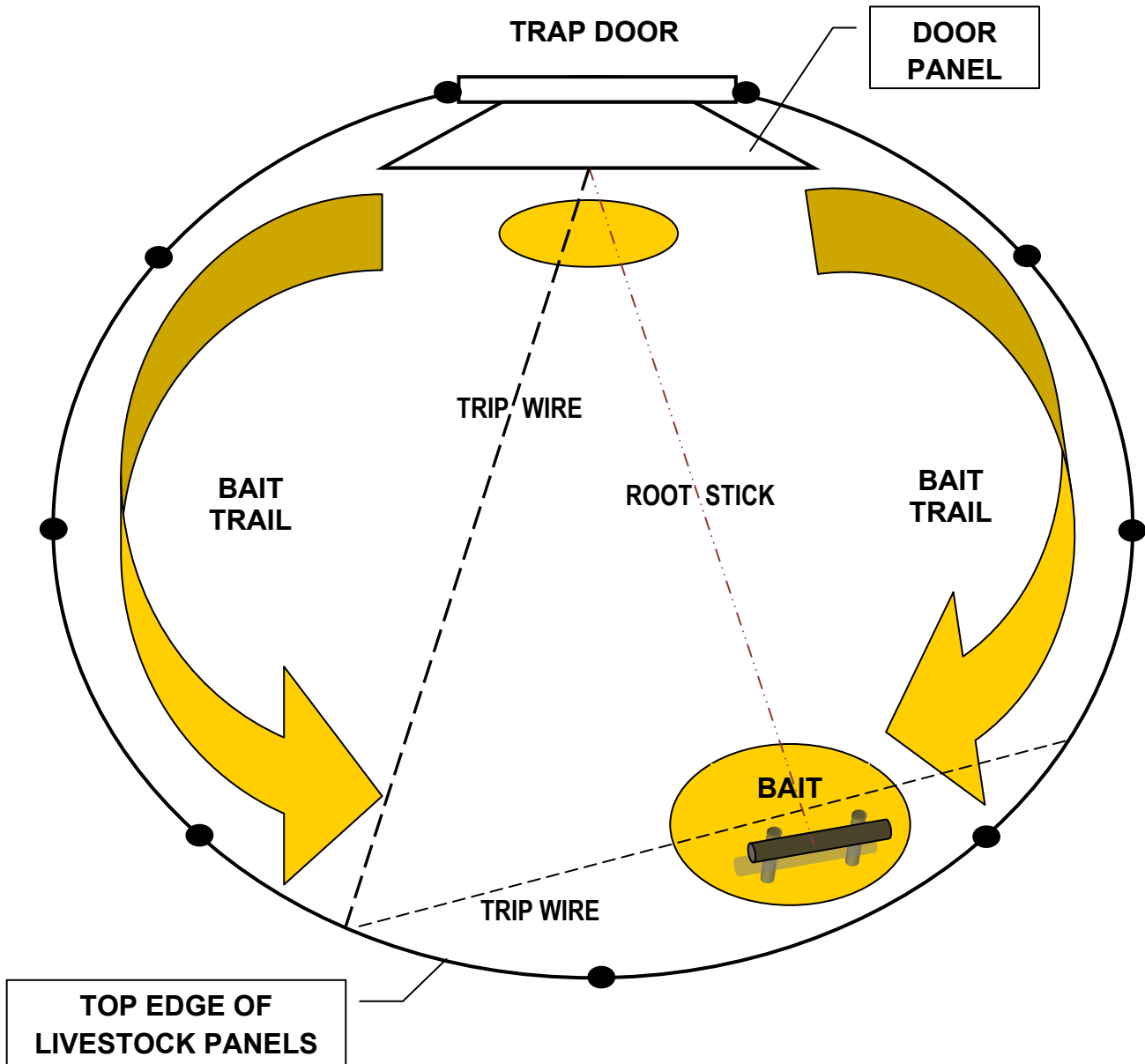

This illustration shows one type of baiting strategy for trapping wild pigs. The rationale behind this strategy is that upon entering the trap, pigs will begin feeding on the bait trails around the inside edge of the trap and slowly work their way to the bait pile located at the back of the trap, allowing more pigs to enter the trap. As they approach the rear bait pile and walk into the trip wire or dislodge the root stick, the tension on the trigger releases the door and the trap is sprung.

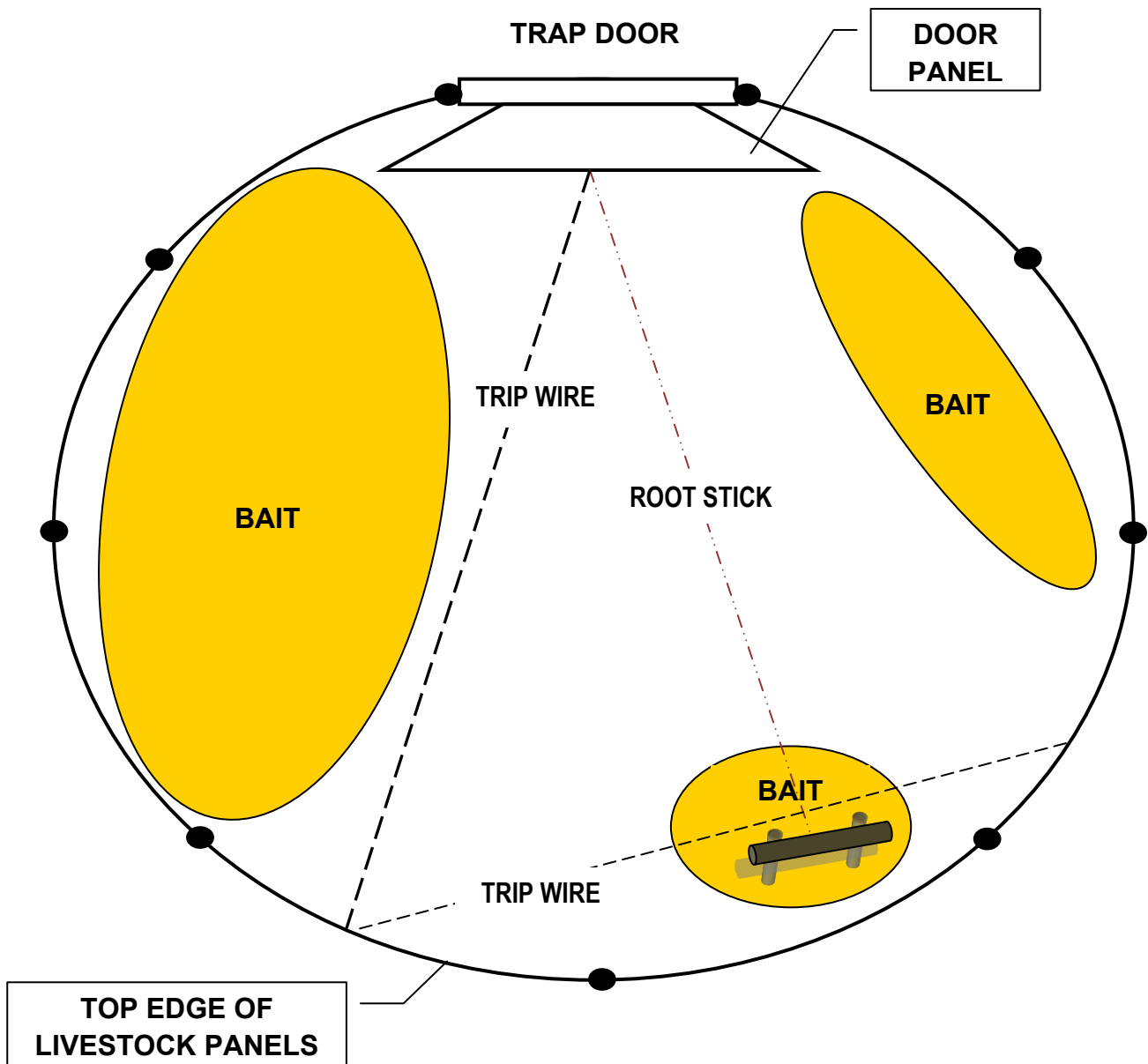

The rationale behind this baiting strategy is that upon entering the trap, pigs will begin feeding on the large bait piles. As more pigs enter the trap, juvenile and subordinate pigs are pushed off the large bait piles. These pigs then migrate to the smaller bait pile at the back of the trap and eventually walk into the trip wire or dislodge the root stick and spring the trap.

APPENDIX III

Kerrville Rooter Gate w/ Trigger
Sht. 1

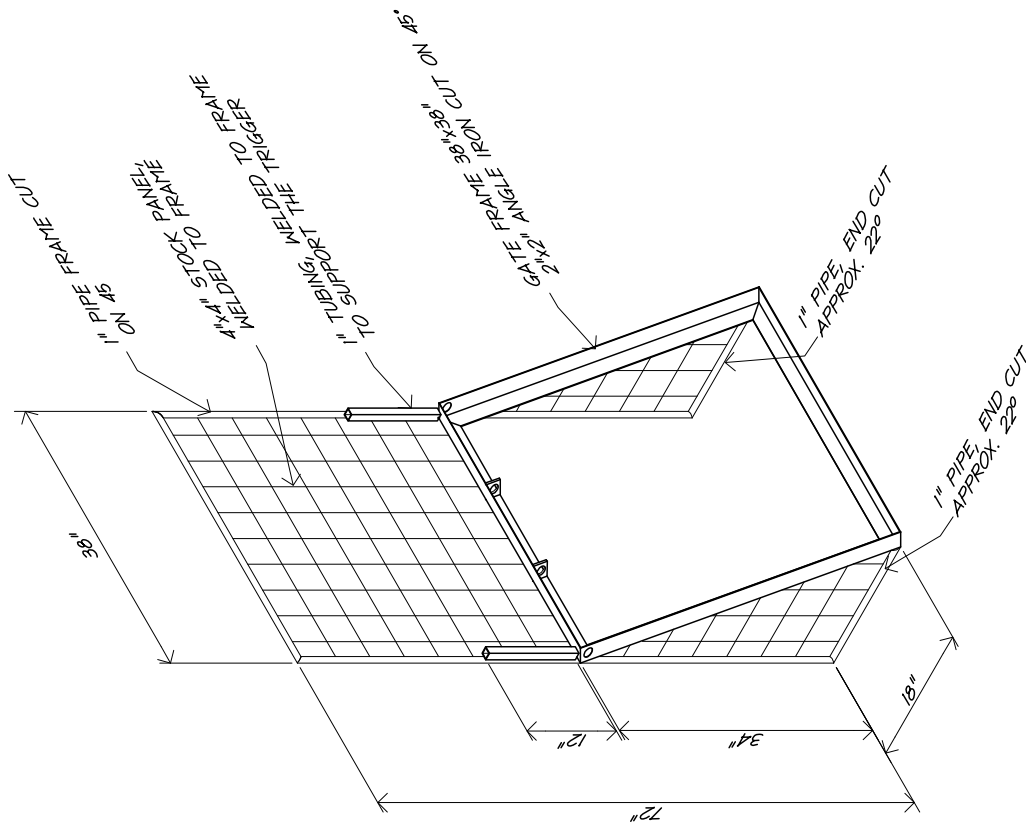
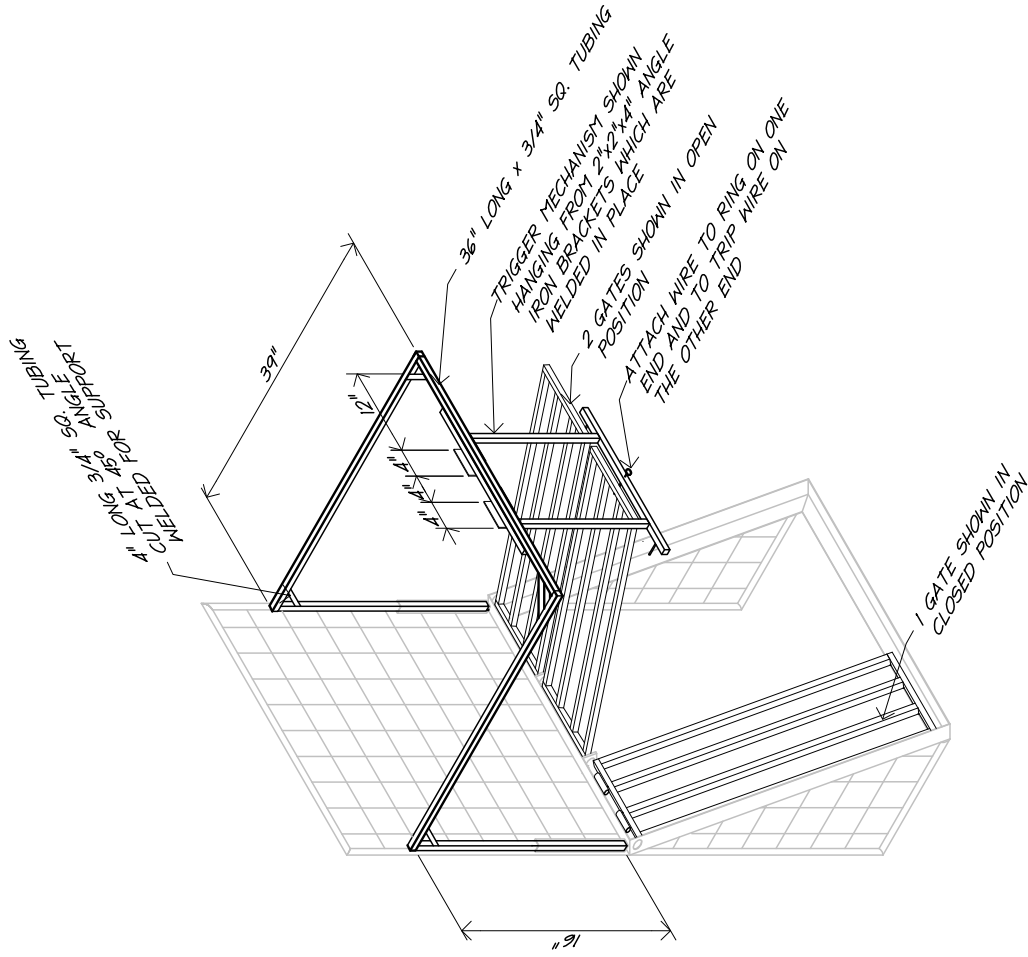

KERRVILLE HOG ROOTER GATE

SCALE: 1/2" = 1'-0"

KERRVILLE HOG ROOTER GATE PANEL

SCALE: 1/2" = 1'-0"



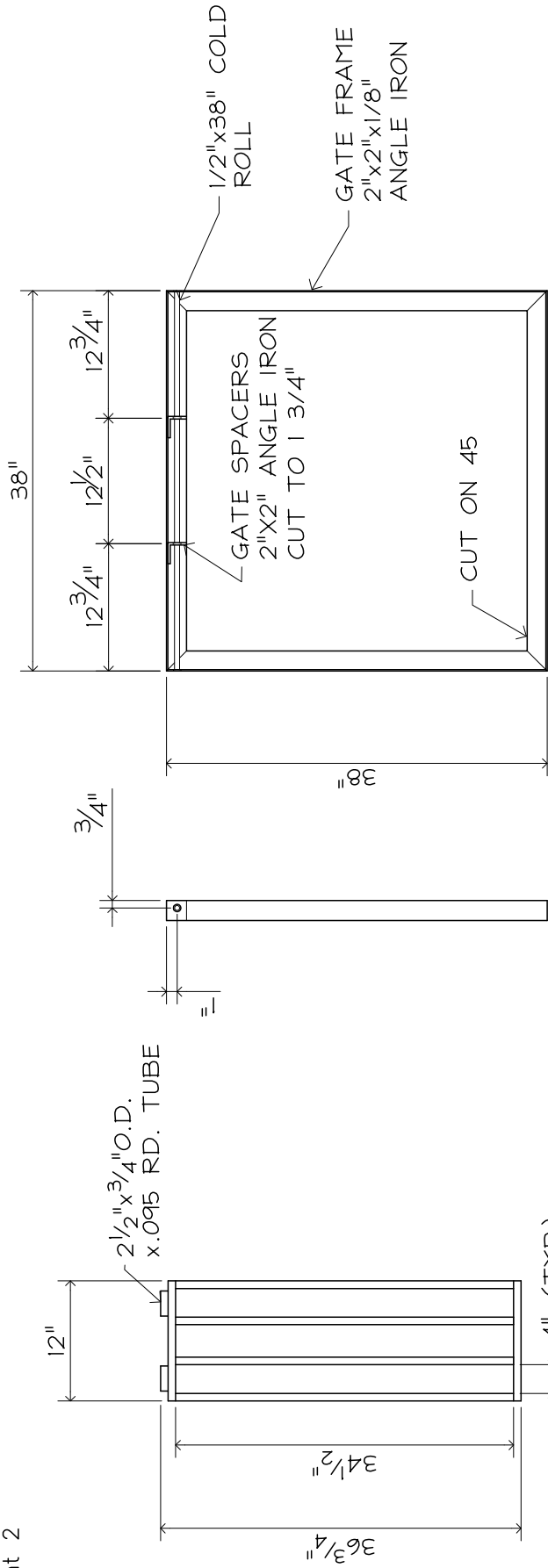

GATE DETAIL (TYPICAL OF 3)

SCALE: 3/4" = 1' - 0"

GATE FRAME DETAIL

SCALE: 3/4" = 1' - 0"

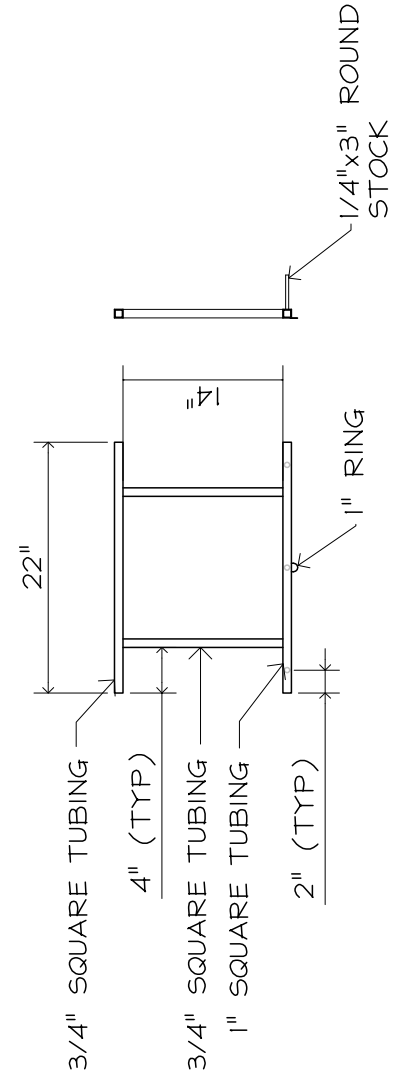

TRIGGER MECHANISM

SCALE: 3/4" = 1' - 0"

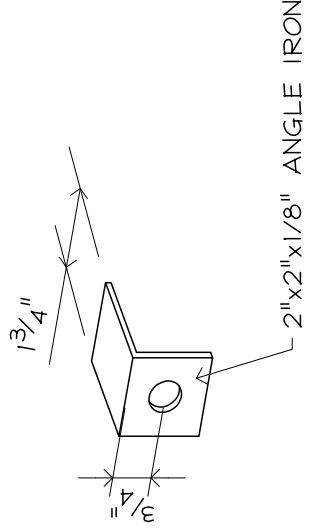

SPACER

SCALE: 3" = 1' - 0"



MATERIALS LIST:

GATE FRAME:

- 14' - 2"x2"x1/8" ANGLE IRON
- 38" - 1/2" COLD ROLL

GATE:

- 42' - 3/4"x3/4" 16 GAUGE Sq. TUBING
- 15" - 3/4" OD ROUND TUBING w/.095 WALL

GATE PANEL:

- 21' - 1" SCH. 40 PIPE

TRIGGER MECHANISM:

- 20' - 3/4"x3/4" 16 GAUGE Sq. TUBING
- 33" - 1"x1" Sq. 14 GAUGE TUBING
- 9" - 1/4" ROUND STOCK
- 1 - 1" RING
- 8" 2x2 ANGLE IRON

OTHER SUPPLIES:

- 14.5 GAUGE WIRE, DOUBLED & TWISTED
- 10 - 6'-6" 'T' POSTS
- 3 - 4x4 WIRE PANELS 16' LONG x 5' MIN. HIGH

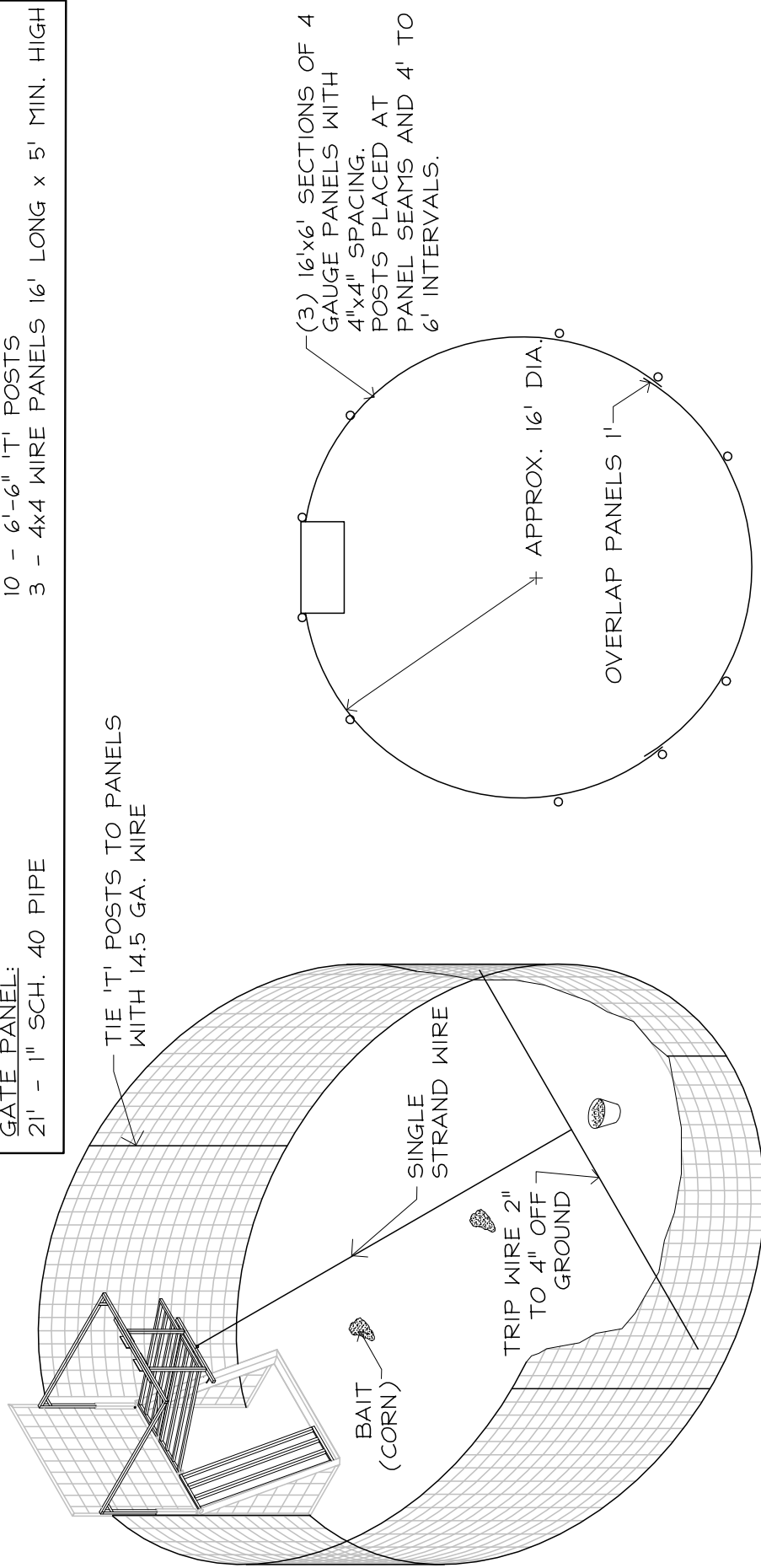

FENCE ISOMETRIC VIEW

NOT TO SCALE

FENCE PLAN VIEW

SCALE: 3/16" = 1'-0"



POOR MAN'S HOG TRAP DOOR

BACK VIEW

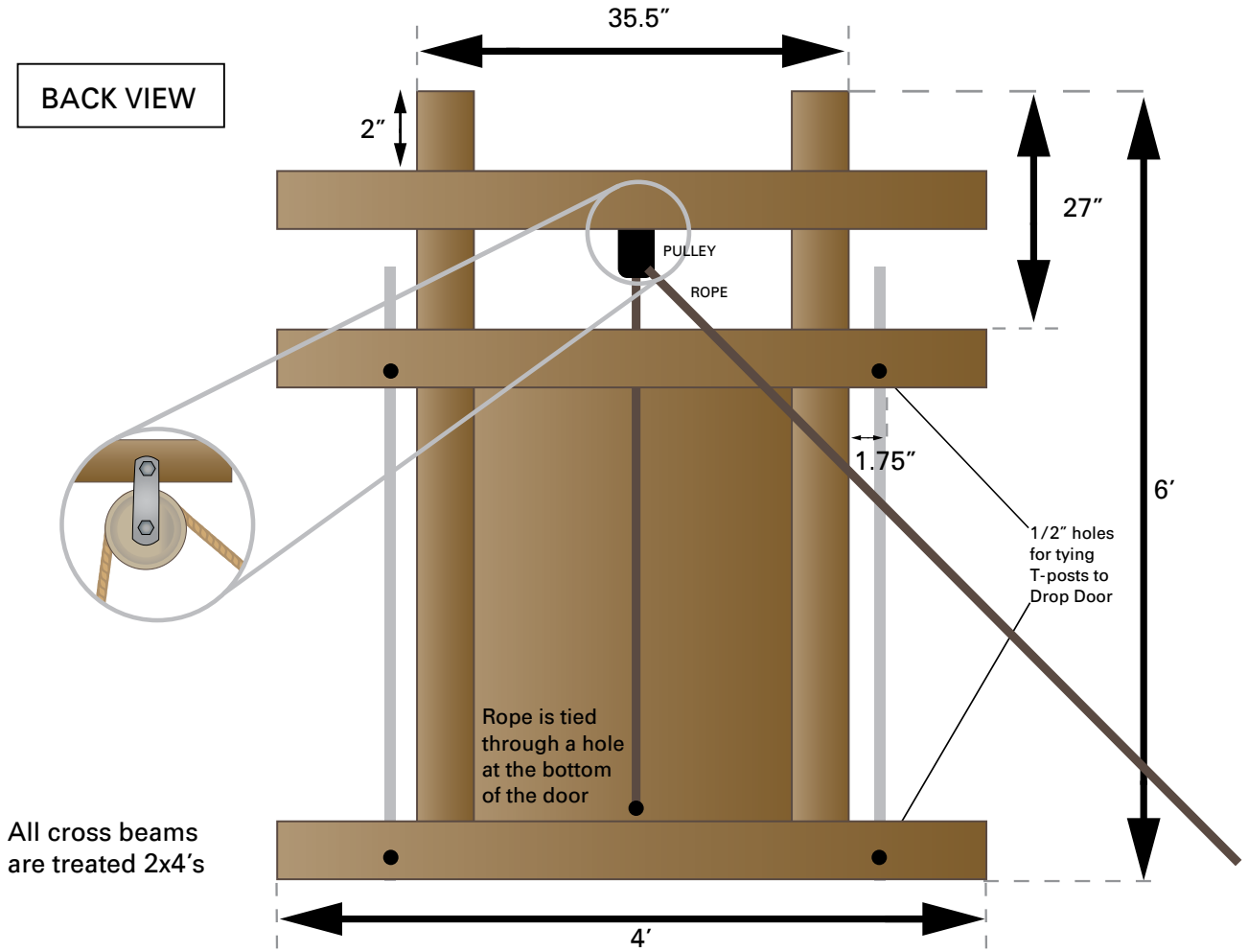

FRONT VIEW

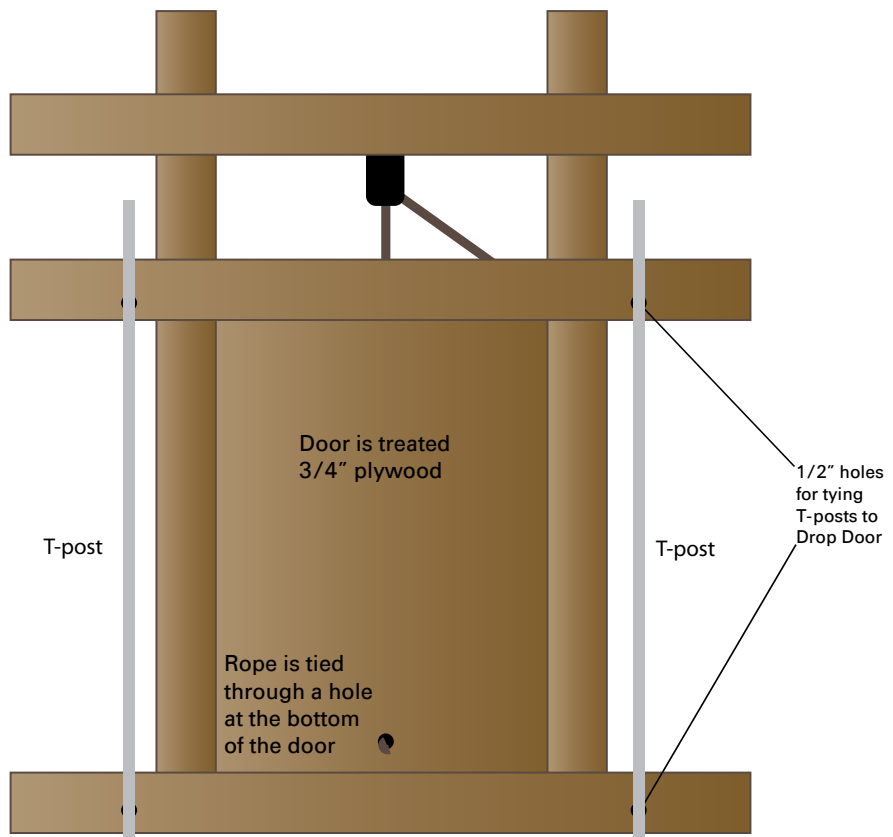

BIRD'S EYE VIEW

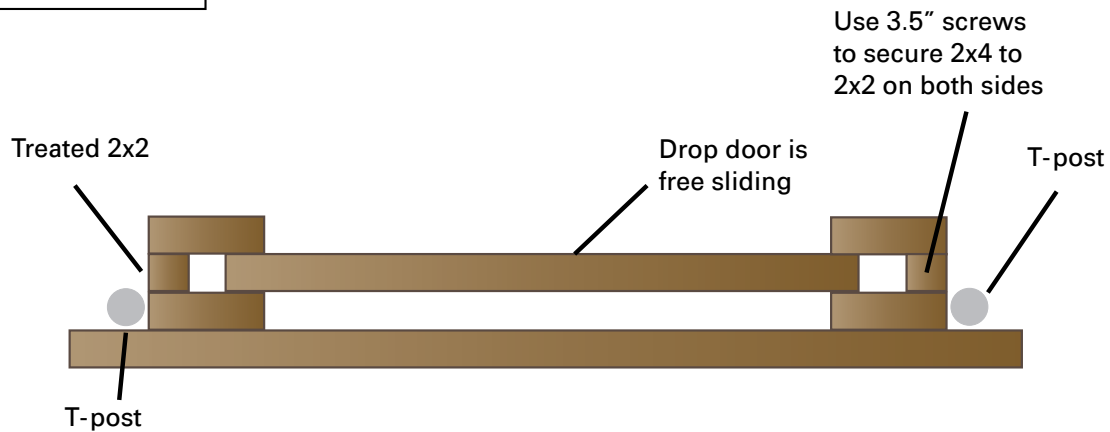

DROP DOOR ONLY

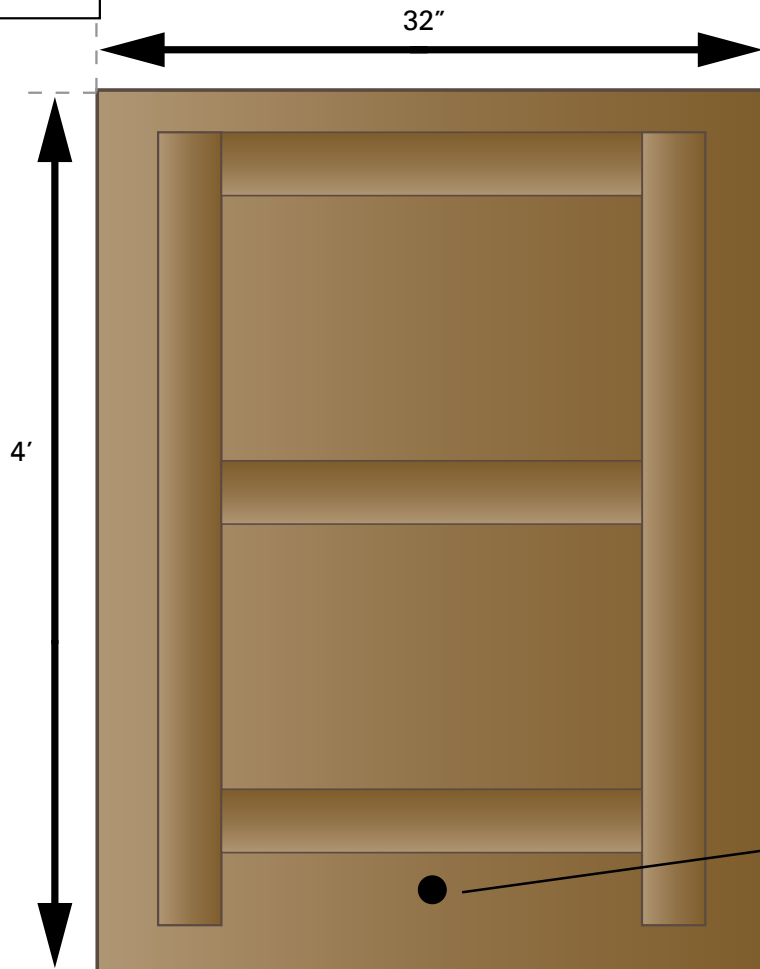

Optional: To keep door from warping over time, use 2x4's as braces on the door as illustrated. It does not matter if the braces face the inside or outside of the trap.

Remember: Make sure the braces are set inside the runners so the door does not jam in the runs.

Tie rope through hole at the bottom of the door and thread through pulley and then to the trigger mechanism. Hole size is 1/2".

Trap Design by Parker Hall Wildlife Biologist

Original Graphics Design by Dana Johnson – Wildlife Biologist – auburnwildlife@bellsouth.net; Illustration by Kathy Jacobs

Trap design may not be reprinted or published in any periodical or web site without the expressed written consent of the above designers, Dr. Jim Armstrong or Andy Whittaker.

Design may be e-mailed to others wishing to build this trap. Check local state game laws before building. Any questions about the trap may be sent to the above e-mail address.

DOUBLE SPRING DOOR OR SALOON-STYLE TRAP DOOR

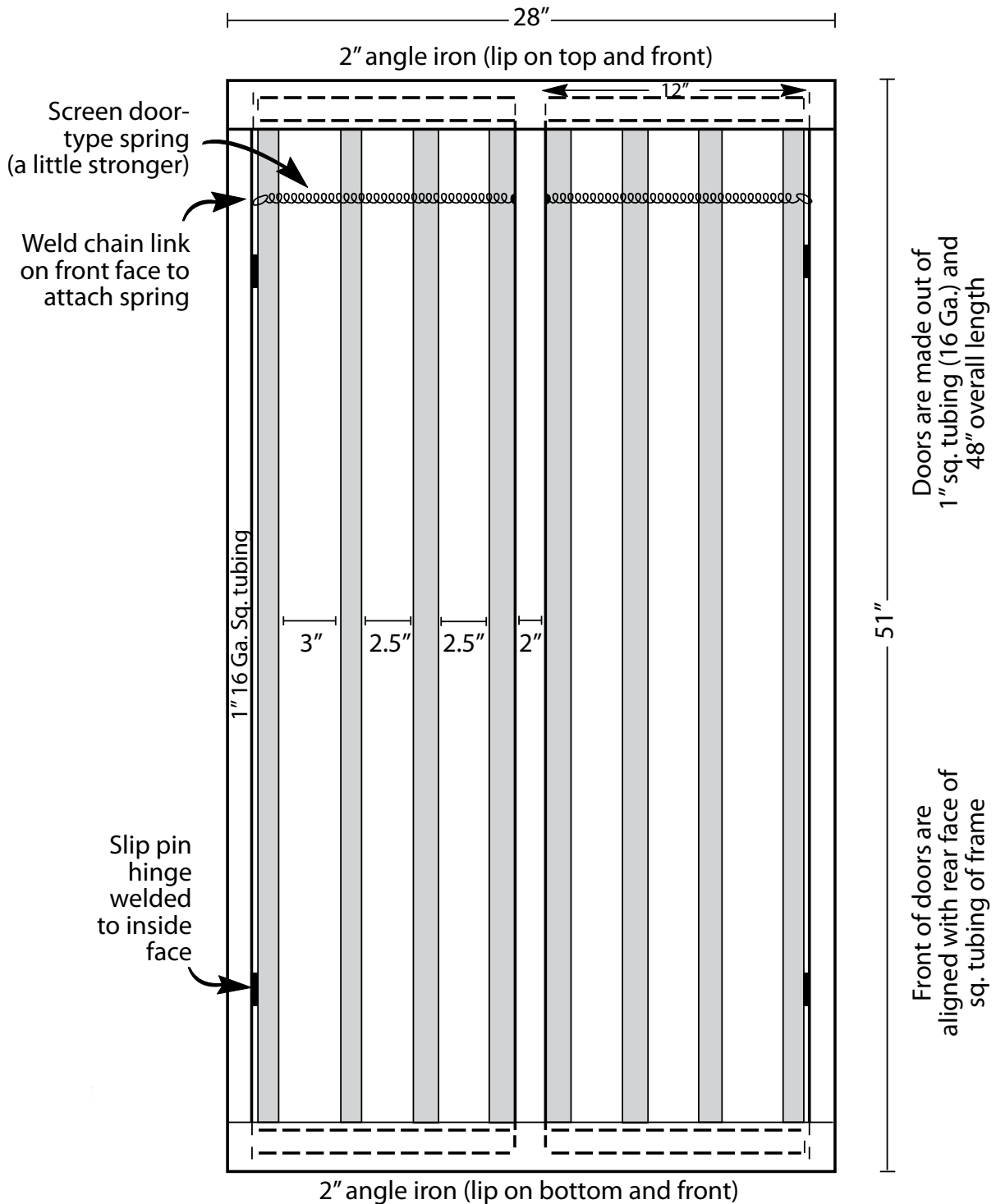

Specifications needed for the construction of a double spring door or saloon-style trap door.

*Adapted from R.L. Stevens' *The Feral Hog in Oklahoma*, The Samuel Roberts Noble Foundation, Ardmore, Oklahoma*

TRIP WIRE

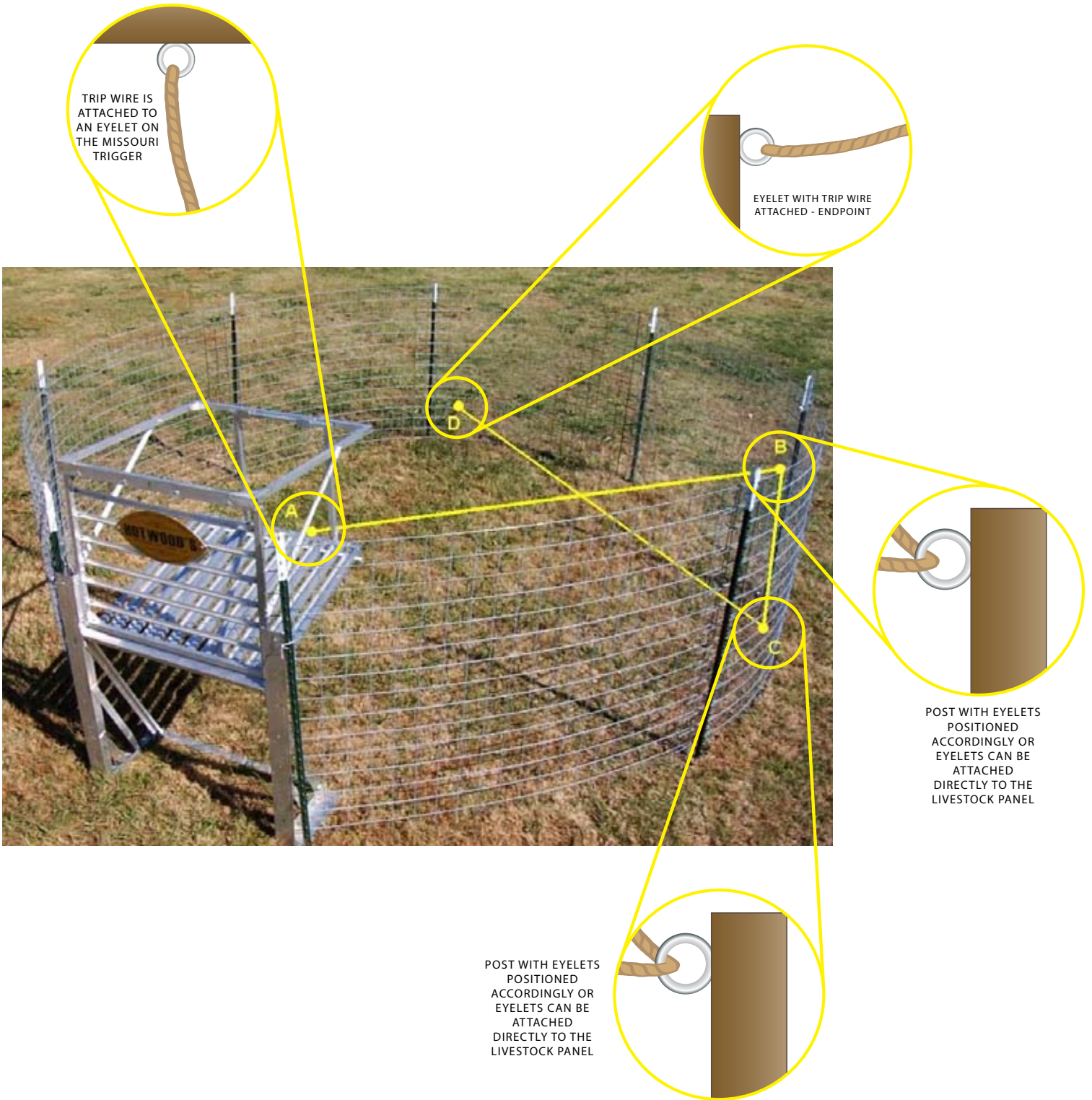

GLOSSARY

- **Boar:** A male pig of any age with intact testicles.
- **Eurasian wild boar:** Free-ranging, wild pigs (male and female) of the “western race” subspecies native to Europe, Russia and the Middle East, extending as far as Central Asia, including central and southern Russia, Kazakhstan, northern Afghanistan, etc.
- **Farrow:** To give birth to pigs.
- **Reportable Disease:** A disease that must be reported to federal, state, or local animal or human health officials when diagnosed.
- **Shoat:** A young pig that has been weaned.
- **Sounder:** A social unit of pigs usually consisting of 2 to 3 related adult sows, their piglets and both juvenile males and females from previous litters.
- **Sow:** A female pig that has farrowed at least once.
- **Zoonotic:** A disease transmissible from animals to humans.

AUTHORS

BILL HAMRICK

Extension Associate II, Department of Wildlife, Fisheries, and Aquaculture, Mississippi State University

MARK D. SMITH

Assistant Professor/Extension Specialist, Alabama Cooperative Extension System, School of Forestry and Wildlife Sciences, Auburn University

CHRIS JAWOROWSKI

Wildlife Biologist, Alabama Department of Conservation and Natural Resources, Division of Wildlife and Freshwater Fisheries - Wildlife Section

BRONSON STRICKLAND

Assistant Professor/Extension Specialist, Department of Wildlife, Fisheries & Aquaculture, Mississippi State University

Support for this project was provided by

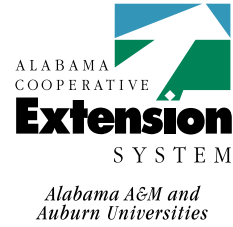

United States Department of Agriculture
National Institute of Food and Agriculture



Copyright 2011 by Mississippi State University. All rights reserved. This publication may be copied and distributed without alteration for nonprofit educational purposes provided that credit is given to the Mississippi State University Extension Service.

Discrimination based upon race, color, religion, sex, national origin, age, disability, or veteran's status is a violation of federal and state law and MSU policy and will not be tolerated. Discrimination based upon sexual orientation or group affiliation is a violation of MSU policy and will not be tolerated.

Publication 2659

Extension Service of Mississippi State University, cooperating with U.S. Department of Agriculture. Published in furtherance of Acts of Congress, May 8 and June 30, 1914. GARY B. JACKSON, Director (02-11)

Publication ANRE-1397, Alabama Cooperative Extension System

